

# Table of Contents

|   |    |
|---|----|
| <b>Healing Cocoon</b> .....                             | 3  |
| <b>Abstract</b> .....                                   | 3  |
| <b>Glossary</b> .....                                   | 3  |
| <b>Introduction</b> .....                               | 3  |
| <i><b>Presentation</b></i> .....                        | 3  |
| <i><b>Motivation</b></i> .....                          | 4  |
| <i><b>Problem</b></i> .....                             | 4  |
| <i><b>Objectives</b></i> .....                          | 4  |
| <i><b>Requirements</b></i> .....                        | 5  |
| <i><b>Tests</b></i> .....                               | 6  |
| <i><b>Report Structure</b></i> .....                    | 6  |
| <b>Background and Related Work</b> .....                | 6  |
| <i><b>Research</b></i> .....                            | 6  |
| <i><b>Introduction</b></i> .....                        | 6  |
| <i><b>Concepts</b></i> .....                            | 7  |
| Healing environments in hospitals .....                 | 7  |
| Digital distraction therapy .....                       | 7  |
| Virtual reality/Smart glasses .....                     | 7  |
| Cocoon environments .....                               | 8  |
| <i><b>Products</b></i> .....                            | 8  |
| Key Players .....                                       | 8  |
| <i><b>Projects</b></i> .....                            | 9  |
| Market Trends .....                                     | 10 |
| <i><b>Comparative Analysis</b></i> .....                | 10 |
| <i><b>Summary</b></i> .....                             | 11 |
| <b>Project Management</b> .....                         | 12 |
| <i><b>Scope</b></i> .....                               | 12 |
| <i><b>Time</b></i> .....                                | 12 |
| <i><b>Cost</b></i> .....                                | 13 |
| <i><b>Quality</b></i> .....                             | 13 |
| <i><b>People &amp; Stakeholder Management</b></i> ..... | 14 |
| <i><b>Communications</b></i> .....                      | 15 |
| <i><b>Risk</b></i> .....                                | 15 |
| <i><b>Procurement</b></i> .....                         | 15 |
| <i><b>Project Plan</b></i> .....                        | 15 |
| <i><b>Sprint Outcomes</b></i> .....                     | 20 |
| <i><b>Sprint Evaluations</b></i> .....                  | 20 |
| <i><b>Summary</b></i> .....                             | 20 |
| <b>Marketing Plan</b> .....                             | 20 |
| <i><b>Introduction</b></i> .....                        | 20 |
| <i><b>Business Idea Formulation</b></i> .....           | 20 |
| <i><b>Business Model</b></i> .....                      | 21 |
| <i><b>Market Analysis</b></i> .....                     | 21 |
| <i><b>SWOT Analysis</b></i> .....                       | 22 |
| <i><b>Strategy</b></i> .....                            | 23 |
| Strategic Objectives .....                              | 23 |
| Segmentation and Targeting .....                        | 23 |
| Positioning .....                                       | 24 |

- Marketing-Mix ..... 25
- Brand ..... 26
- Marketing Programmes** ..... 27
- Programmes ..... 27
- Budget ..... 27
- Control ..... 27
- Summary** ..... 28
- Eco-efficiency Measures for Sustainability** ..... 28
- Introduction** ..... 28
- Environmental** ..... 29
- Economical** ..... 29
- Social** ..... 30
- Life Cycle Analysis** ..... 30
- Summary** ..... 31
- Ethical and Deontological Concerns** ..... 31
- Introduction** ..... 31
- Engineering Ethics** ..... 31
- Sales and Marketing Ethics** ..... 32
- Environmental Ethics** ..... 32
- Liability** ..... 33
- Summary** ..... 33
- Project Development** ..... 34
- Introduction** ..... 34
- Ideation** ..... 34
- Concept** ..... 34
- Design** ..... 34
- Structure ..... 34
- Smart System ..... 37
- Packaging ..... 41
- Prototype** ..... 41
- Structure ..... 41
- Hardware ..... 41
- Software ..... 42
- Tests & Results ..... 51
- Summary** ..... 51
- Conclusions** ..... 51
- Achievements** ..... 51
- Limitations** ..... 51
- Future Development** ..... 51
- Acknowledgements** ..... 52
- Bibliography** ..... 52

# Healing Cocoon

- Ronja Kruse
- Hanna Kaczmarek
- Kemal Yilmaz
- Anouc Baindu Goedhart
- Daniel Aagaard Pérez
- Julie Bonnet

2026/02/16 22:34 · epsatisep · [0 Comments](#)

## Abstract

2026/02/16 22:31 · epsatisep · [0 Comments](#)

## Glossary

| Abbreviation | Description                                |
|--------------|--|
| 6-V          |  |
| ADHD         |  |
| AR           | Augmented Reality                          |
| B2B          |  |
| EPS          | European Project Semester                  |
| ISEP         | Instituto Superior de Engenharia do Porto  |
| LCA          | Life Cycle Assesment                       |
| MCDAS        | Modified Child Dental Anxiety Scale        |
| SWOT         | Strengths Weaknesses Opportunities Threats |
| USB          | Universal Serial Bus                       |
| VR           | Virtual Reality                            |
| ROMI         | Return on Marketing Investment             |
| ROI          | Return on Investment                       |
| KPI          | Key Performance Indicators                 |
| WBCSD        |  |

2026/02/16 22:32 · epsatisep · [0 Comments](#)

## Introduction

### Presentation

This project, a collaborative effort by six European students, focuses on enhancing child well-being

during the pre-visit phase. By blending engineering and creative design, we aim to transform the waiting experience through interactive digital art. As illustrated in Table 1, this multidisciplinary strategy ensures our intervention is inclusive, comforting, and tailored to the emotional needs of young users.

Table 1: caption

| Name                  | Country     | Studies                       |
|-----------------------|-------------|-------------------------------|
| Ronja Kruse           | Denmark     | Dental Technology             |
| Hanna Kaczmarek       | Poland      | Industrial Biotechnology      |
| Anouc Daindu Goedhart | Netherlands | Industrial Design Engineering |
| Daniel Aagaard Pérez  | Spain       | Informatics Engineering       |
| Julie Bonnet          | France      | Packaging Engineering         |
| Kemal Yilmaz          | Belgium     | Electronics - ICT             |

## Motivation

Hospital and waiting rooms can be stressful and uncomfortable for many patients, especially for children or people who need to stay for a longer period of time. Clinical healthcare environments are often designed mainly for medical efficiency rather than emotional comfort.

Research shows that the surrounding environment can influence patient well-being and recovery. Calming visual elements or familiar environments can help reduce stress and improve emotional comfort.

This project is motivated by the idea that technology can be used to create more comforting and supportive healthcare environments without requiring major physical changes. Immersive visual technologies offer new ways to improve patient experiences during the waiting time for a medical appointment or hospitalization.

## Problem

Medical environments are often designed for medical efficiency rather than patient comfort, which can make them feel cold and impersonal. This can increase stress and anxiety for patients, especially due to unfamiliar surroundings and medical procedures. Research shows that calming visual environments or natural elements can help reduce stress and support recovery. However, many medical areas still lack accessible solutions to create more comforting and engaging environments for patients.

## Objectives

The main objective of this project is to explore how immersive projection technology can improve the emotional experience of patients (especially children) in medical environments.

The specific objectives of the project are:

- To investigate how medical and hospital environments influence patient stress and recovery

- To explore existing technologies such as projection systems, immersive environments, and digital distraction therapy
- To develop a concept that transforms hospital or waiting rooms into calming and personalized spaces
- To reduce stress and anxiety for patients during hospitalization/waiting time
- To improve the overall patient experience through design and technology

The overall goal of the project is to design a concept that can create a more comforting and supportive hospital environment, particularly for children and long-term patients.

## Requirements

*Specify here the identified and mandatory requirements the solution has to fulfil*

### Requirements

The proposed solution must meet the following requirements:

#### User & Experience Requirements:

- The system must reduce patient stress and anxiety during waiting or treatment periods.
- The system must create a calming and comfortable environment using visual and sensory elements.
- The system must be suitable for children and adaptable to different age groups.
- The system must provide a sense of safety and personal space for the user.

#### Healthcare Environment Requirements:

- The system must be suitable for use in hospital or waiting room environments.
- The system must not interfere with medical equipment or workflows.
- The system must comply with hygiene standards for shared healthcare environments.
- The system must be easy to clean and maintain.

#### Functional Requirements:

- The system must provide immersive visual content (e.g. projection or display).
- The system must integrate at least two sensory elements (e.g. visual, audio, scent, or movement).
- The system must be easy to operate by healthcare staff.
- The system must allow quick setup and minimal preparation time.

#### Accessibility Requirements:

- The system must be accessible for users with reduced mobility (e.g. wheelchair users).
- The system must allow safe entry and exit.

#### Technical & Design Requirements:

- The system must be safe for use in indoor healthcare environments.
- The system must operate with low noise levels.
- The system must be energy-efficient.

- The system must have a compact footprint suitable for limited spaces.

These requirements are derived from user needs, healthcare constraints, and insights from the state-of-the-art analysis

## Tests

## Report Structure

| Chapter                                      | Description                               |
|--|---|
| 1 Introduction                               | ...                                       |
| 2 Background and related work                | Existing research and studies             |
| 3 Project Management                         | ...                                       |
| 4 Marketing Plan                             | ...                                       |
| 5 Eco-efficiency Measures for Sustainability | ...                                       |
| 6 Ethical and Deontological Concerns         | ...                                       |
| 7 Project Development                        | ...                                       |
| 8 Conclusions                                | ...                                       |
| 9 Acknowledgements                           | Bibliography of sources and articles used |

2026/02/16 21:05 · epsatissep · [0 Comments](#)

## Background and Related Work

*This chapter provides the reader with the relevant technical-scientific background as well as existing related products and research, also known as the state of the art, in the field(s) of the project.*

## Research

Here we can put a small summary of our research.

## Introduction

Research shows that the environment in healthcare facilities has a significant impact on patient well-being and recovery. Sterile and impersonal environments can increase stress and anxiety, especially in children prior to medical procedures. Studies using the Modified Child Dental Anxiety Scale (MCDAS) report anxiety prevalence rates between 13.3% and 29.3% [\[1\]](#).

Introducing calming visual elements such as nature imagery, colors, and familiar environments can help reduce psychological stress and improve emotional comfort. In this context, digital technologies such as projection systems and virtual reality are increasingly used to create immersive and engaging

environments. These technologies aim to distract patients from anxiety, pain, and medical procedures, thereby improving the overall patient experience.

## Concepts

*Provide here all relevant concepts related to the topic(s) of the project*

### Healing environments in hospitals

The physical environment of hospitals can have a significant influence on patient recovery and well-being. A study made in 2025 [2] show that the stress and anxiety experienced by patients during waiting periods can be reduced through a color-light interaction design system. The current sterile and neutral hospital/waiting rooms should include more calming elements such as colors, natural imagery, and familiar visual environments, in order to help create a more healing and welcoming atmosphere.

In addition, sensory stimuli such as scent can influence patient experience. For example, scents like orange and lavender have been shown to reduce stress and anxiety levels [3]. When applied before treatments, patients demonstrate calmer and less anxious behavior.

### Digital distraction therapy

Digital distraction therapy is increasingly used in healthcare to help patients cope with stress, anxiety, and pain. The idea behind distraction therapy is to shift the patient's attention away from medical procedures or discomfort [4]. Examples include:

- Virtual Reality (VR) headsets which have been shown to significantly reduce anxiety and pain perception in pediatric patients during medical procedures [5], [6].
- Interactive walls and projection systems have been implemented in hospitals to create engaging environments that distract patients and improve emotional comfort [7], [8].
- Digital games and immersive environments have been explored as effective tools to increase patient engagement and reduce perceived stress in healthcare settings [9].

These findings highlight the importance of distraction as a mechanism for reducing anxiety. However, many existing solutions rely on screens or wearable devices. This project builds on these insights by creating a more immersive, non-wearable environment that integrates distraction into the surrounding space.

### Virtual reality/Smart glasses

Virtual Reality (VR) and smart glasses provide immersive or augmented visual experiences directly in the patient's field of view. VR technology is widely used in healthcare to reduce anxiety by immersing patients in virtual environments.

Al-Nerabieah et al. (2020) [10] evaluated the impact of VR eyeglasses in a dental waiting room and found that their use significantly decreased anxiety levels in children aged 6–10 years. While VR offers high levels of immersion, it requires wearable devices, which may be uncomfortable or impractical in some healthcare situations. VR demonstrates the strong impact of immersive environments on anxiety reduction. However, the reliance on wearable devices introduces limitations in hygiene, comfort, and usability. This project takes inspiration from the immersive aspect of VR, while eliminating the need for wearables.

## Cocoon environments

Cocoon environments are designed to create a protected and calming space around the patient. The idea of a cocoon is to reduce the feeling of being in a clinical hospital environment and instead provide a sense of safety, comfort, and privacy. In healthcare design, a cocoon concept often uses visual elements, lighting, or digital technology to surround the patient with soothing stimuli. This can help reduce stress, anxiety, and sensory overload during hospitalization. Examples include:

- Immersive projection environments that transform spaces into calming scenes, such as nature or abstract environments, have been shown to reduce stress and improve emotional well-being in healthcare settings were successfully tested in this study [11].
- Soft lighting systems combined with visual environments, such as natural or familiar imagery, can create a more relaxing atmosphere in patient rooms and improve emotional comfort were tested by this study [12].
- Enclosed or semi-enclosed relaxation spaces can provide patients with a sense of privacy and safety, reducing external stimuli and contributing to lower stress levels were explored by [13]

These concepts form the foundation of the proposed solution. By combining immersion, multisensory stimulation, and a semi-enclosed structure, the cocoon integrates the most effective elements identified in the literature. This allows the design to create a controlled, calming environment that enhances both emotional comfort and anxiety reduction.

## Products

*Search, select and describe related commercial solutions*

Market Analysis – Healing Spaces

Competitor Landscape There are several established companies focusing on transforming hospital environments through immersive and sensory design solutions.

## Key Players

### Direct Competitors

#### Philips Healthcare – Ambient Experience

What they do: Philips Healthcare [14] is a market leader in creating immersive healthcare environments by integrating dynamic lighting, video projection, and sound into treatment spaces such

as MRI and CT rooms.

Strengths: Highly professional and medically certified solution, seamlessly integrated into hospital architecture, with proven impact on reducing patient anxiety.

Weaknesses: Extremely expensive and primarily focused on diagnostic environments (MRI/CT), making it less accessible for everyday patient rooms or long-term care settings.

### **Qwiek (Qwiek.up)**

What they do: Qwiek [15] is a Dutch company that develops mobile projection systems designed for use in healthcare environments, particularly in elderly care and hospitals. The system projects calming visuals, such as nature scenes, onto walls or ceilings to create a more relaxing atmosphere for patients.

Strengths: Mobile and easy to use, allowing the device to be moved between rooms. The system is accessible and requires minimal setup, making it suitable for various healthcare settings.

Weaknesses: The device is a standalone floor unit, which takes up space in already crowded environments. In addition, the level of interactivity is limited, offering mainly passive visual experiences with minimal user engagement.

This solution demonstrates the potential of projection-based environments but lacks immersion and a sense of personal, enclosed space, which our cocoon concept aims to provide.

## **Indirect Competitors & Substitutes**

### **SyncVR Medical**

What they do: SyncVR Medical [16] is a Dutch company that provides Virtual Reality (VR) solutions for healthcare. Their platform offers immersive VR experiences designed to reduce pain, anxiety, and stress during medical procedures, particularly in pediatric and clinical settings.

Strengths: Highly immersive experience that effectively distracts patients from medical procedures. Proven to reduce anxiety and pain perception. The system is relatively portable and can be used across different departments.

Weaknesses: Requires wearable VR headsets, which raises hygiene concerns in shared environments. Some patients may feel uncomfortable or disoriented when using VR. In addition, setup and supervision are often required, making it less practical for continuous or large-scale use.

This highlights the limitations of wearable VR solutions in healthcare, reinforcing the need for immersive, non-wearable environments such as the proposed cocoon concept.

## **Projects**

*Search, select and describe related research projects*

## Market Trends

### Evidence-Based Design (EBD)

Hospitals are increasingly designed based on scientific evidence showing that the physical environment influences patient recovery, stress levels, and overall well-being. Design elements such as lighting, color, and visual stimuli are used to create more supportive healing environments. An example of this approach can be seen in the Princess Máxima Center for Pediatric Oncology, where the environment is specifically designed to improve patient experience.

Research [17] shows that the physical hospital environment directly influences patient recovery, stress levels, and overall well-being.

### Staff Shortages & Efficiency

Healthcare systems are increasingly facing staff shortages, creating a demand for solutions that can support patient care without requiring constant supervision. Technologies that help calm, distract, or engage patients can reduce the workload on healthcare professionals.

Design interventions and environmental solutions can reduce patient stress while simultaneously improving workflow efficiency, helping to relieve pressure on healthcare staff [18].

## Comparative Analysis

To determine the most effective solution for reducing anxiety in children, various existing technologies and approaches were analyzed and compared. This comparison focuses on key criteria such as immersion, comfort, hygiene, ease of use, and feasibility in healthcare settings.

VR Headsets offer a highly immersive experience by completely blocking out the real world and placing the user in a virtual environment. This can help reduce anxiety and stress, and research [19] shows that VR can be effective in distracting children during medical procedures. However, VR also has a number of disadvantages. In shared environments such as waiting rooms, hygiene is a concern, as the headset must be cleaned after each use. Some children may also feel uncomfortable wearing a headset, especially if they are already anxious. Furthermore, the time required to set up and reset the device makes it less practical for multiple users.

Smart glasses or Augmented Reality (AR) glasses are an innovative solution that combines digital elements with the real world. They are lighter than VR headsets and allow the user to remain aware of their surroundings while still interacting with virtual content. On the other hand, this technology is still relatively expensive and has not yet been widely adopted in healthcare. The level of immersion is also lower than with VR, making this technology less effective as a distraction. Therefore, AR glasses are currently less suitable for these types of applications.

Projection-based environments create immersive images on walls or surfaces without requiring the user to wear a device. This makes them highly accessible, hygienic, and user-friendly for multiple children. However, the experience is less immersive compared to other solutions. Children remain aware of the waiting room, which can reduce the calming effect. Furthermore, there is a lack of a sense of a personal or protected space, which is important for children with anxiety symptoms.

Multisensory cocoon (our solution) combines various sensory elements, such as visuals, sound, scent,

and gentle movements, into a single environment. It creates a semi-enclosed space that gives children a sense of security and reduces external stimuli. Compared to other options, the cocoon offers a better balance between immersion and comfort. No wearable devices are required, making it more hygienic and easier to use in shared environments, while the combination of multiple senses promotes relaxation and distraction. The main downsides are that it requires physical installation and that the design is more complex compared to simpler solutions. However, these challenges are acceptable given the benefits the cocoon offers. Furthermore, the cocoon can be designed to be inclusive and accessible to all users, for example by making the seats removable and integrating a small ramp, allowing children in wheelchairs to easily enter and use the system.

To support the comparison, a decision matrix was created using key evaluation criteria. Each solution was scored from 1 (low) to 5 (high). Table 2 provides the result.

Table 2: Add caption

| <b>Solution</b> | <b>Immersion</b> | <b>Comfort</b> | <b>Hygiene</b> | <b>Practicality</b> | <b>Feasability</b> | <b>Total</b> |
|-----------------|------------------|----------------|----------------|---------------------|--------------------|--------------|
| VR Headset      | 5                | 2              | 2              | 2                   | 3                  | 14           |
| AR Glasses      | 3                | 2              | 2              | 2                   | 2                  | 11           |
| Projection      | 3                | 4              | 5              | 4                   | 4                  | 20           |
| Cocoon          | 4                | 5              | 4              | 4                   | 3                  | 20           |

Although projection systems and the cocoon achieve similar total scores, projection-based solutions lack the ability to create a personal and protected environment. For children experiencing anxiety, a sense of safety and reduced external stimuli is essential.

The cocoon provides a semi-enclosed, multisensory environment that enhances both emotional comfort and immersion. By combining the advantages of projection systems with a protected spatial design, the cocoon addresses the key limitations of existing solutions.

Therefore, the multisensory cocoon is considered the most suitable solution for reducing anxiety in pediatric healthcare environments.

## Summary

*Provide here the conclusions of this chapter and make the bridge to the next chapter.*

Based on the state-of-the-art analysis, it can be concluded that existing solutions such as Virtual Reality, Augmented Reality, and projection systems each offer specific advantages in reducing anxiety in healthcare environments. However, none of these solutions fully combine immersion, comfort, hygiene, and practicality.

The selected approach combines projection-based visualization techniques, multisensory stimulation, and a semi-enclosed spatial design to create a controlled and calming environment around the patient.

Key components of the system include a short-throw projector, integrated speakers, a scent diffuser, ambient lighting elements, and a supportive seating structure within an enclosed shell.

This solution was chosen because it provides an optimal balance between immersion, comfort,

hygiene, and practicality. Unlike VR systems, it does not require wearable devices, making it more suitable for shared healthcare environments. Compared to projection-only systems, the enclosed structure enhances the sense of safety and reduces external stimuli, which is essential for reducing anxiety in children.

Therefore, the proposed concept is an evidence-based multisensory cocoon that combines the advantages of existing technologies while addressing their limitations.

The next chapter will focus on the project management approach, describing how the project was structured, planned, and executed throughout the development of the cocoon concept.

2026/02/16 21:06 · epsatissep · [0 Comments](#)

## Project Management

In this chapter, we will develop our project management approach by describing several aspects such as the scope, time, project plan and our understanding and use of Jira, particularly with sprints.

### Scope

The scope of our project focuses on the research and development of a solution up to the proof-of-concept stage. Indeed, in this project, we are following the demonstration process to prove that the solution we propose can be developed and be viable in the future.

Boundaries of the project: We are studying and developing the idea of a Healing Cocoon to reduce children's anxiety in the waiting room before a medical appointment. We are focusing on the structure, design, materials, app and devices.

Product scope (*extent of what the project will produce*): Throughout the project, deliverables will be produced, such as: flyer, leaflet, 3D models, drawings, designs, detailed schematics.

Project scope (*summary of the work needed to produce it = WBS still to do*)

### Time

To make sure we finish this project within the 15-week semester, we break our work down into small, weekly goals. We use task-tracking software to organize who is doing what every week. This flexible approach allows us to design the physical pod and write the software at the same time. While our weekly tasks are flexible, we make sure to always pay attention to the major deadlines and closely monitor progress over time.

Here the details of the milestones of our project:

**2026-02-28** Choose and share top-3 preferred project proposals via email (epsatissep@gmail.com)

**2026-03-11** Upload "black box" System Diagrams & Structural Drafts to Deliverables

**2026-03-18** Upload List of Components and Materials (Deliverables)

**2026-03-21** Define the Project Backlog (what must be done and key deliverables - every member

should preferably participate in every task), [Global Sprint Plan](#), Initial Sprint Plan (which tasks should be included, who does what) and [Release Gantt Chart of the project](#) and insert them on the wiki (Report)

**2026-03-25** Upload [detailed System Schematics & Structural Drawings](#) (Deliverables) and do the [cardboard scale model](#) of the structure

**2026-04-12** Upload [Interim Report and Presentation](#) (Deliverables)

**2026-04-16** Interim Presentation, Discussion and Peer, Teacher and Supervisor feedbacks

**2026-04-22** Upload [3D model video](#) (Deliverables)

**2026-04-29** Upload [final List of Materials](#) (local providers & price, including VAT and transportation) to Deliverables

**2026-05-02** Upload [refined Interim Report](#) (based on Teacher & Supervisor Feedback)

**2026-05-13** [Packaging solution](#) (Deliverables and Report)

**2026-05-27** [Results of the Functional Tests](#) (Report)

**2026-06-13** [Final Report, Presentation, Video, Paper, Poster and Manual](#) (Deliverables)

**2026-06-18** [Final Presentation, Individual Discussion and Assessment](#)

**2026-06-23** Update the [wiki, report](#) (suggested corrections), upload [refined deliverables](#) in shared section of MS Teams (source and PDF), [printed copy of the poster, brochure and leaflet](#) for EPS coordinator

**2026-06-25** [Submit prototype and user manual, prototype demonstration](#)

## Cost

We need to clearly separate two different prices: the price of the final product and the budget we have right now. While the final Healing Cocoon will be sold to clinics for about 2000€ to 2500€, our goal right now is just to build a working test model (prototype) to prove our technology works.

For this first prototype, the EPS program gave us a 100€ budget limit. To make sure we don't spend too much, we are using affordable, easy-to-find materials for the physical frame. For the smart system, we are using low-cost electronic sensors and a basic microcontroller (ESP32).

Table 3: Planned vs. Actual Costs

| Required component     | Description   | Total Budget (€) | Actual Costs (€)        |
|------------------------|---|------------------|-------------------------|
| Smart brain & sensors  | ESP32 board, and sensors for light, carbon dioxide and humidity | 25.00            | 23.67                   |
| Output devices         | Scent sprayer, speaker amplifier, and relay switch              | 25.00            | 22.98                   |
| Power supply           | 5 V 2 A USB wall plug   | 25.00            | 7.26                    |
| Building materials     | Fiberglass rods, hula hoop, spandex, acoustic foam, PVC         | 40.00            | 0.00 (Pending purchase) |
| Total prototype budget |   | 100.00           | 53.91                   |

## Quality

To make sure the Healing Cocoon is safe for children and works perfectly in a real clinic, we set clear quality goals. We constantly check our work through team reviews, teacher feedback, and physical testing.

## Building & Hardware Quality

- Wheelchair access - The opening and inside of the pod must be big enough for a standard child's wheelchair to roll right in without the child needing to stand up.
- Cleanliness & Hygiene - All inside surfaces must be easy to wipe down and made of materials that stop germs from spreading. They must also survive standard clinic cleaning sprays without getting damaged. This will be done by checking the manufacturer's safety sheets and testing the materials with cleaning sprays.
- Fast Electronics - When the smart system (the ESP32) senses something, the lights, sounds, or scents must react in less than 2 seconds so the experience feels magical and natural. This is going to be tested by running the code and testing the electronics over and over to find any delays.

We are also focusing on clear and consistent report for keeping the track of our progress and milestones achieved. We use a final "cross-check checklist" before submission, ensuring all numbers, part names, and deadlines match across every single chapter.

## People & Stakeholder Management

To make sure our project runs smoothly, we have clearly defined the roles of our internal team members and identified the external groups (stakeholders) who care about the success of the Healing Cocoon.

**The Project Team (Internal)** Our team is made up of six international students from different academic backgrounds. Because we have different skills, we divided the project responsibilities to match our strengths:

1. Ronja Kruse (Dental Technology): Provides medical insights for the clinic environment, helps with B2B marketing, and designs the wheelchair-accessible layout.
2. Hanna Kaczmarek (Industrial Biotechnology): Focuses on ergonomic dimensions, market analysis, and the business SWOT analysis.
3. Anouc Goedhart (Industrial Design Engineering): Leads the 3D design models, branding (flyers/leaflets), and the visual identity of the Cocoon.
4. Daniel Aagaard Pérez (Informatics Engineering): Develops the software app, the user interface (UI), and the detailed technical schematics.
5. Julie Bonnet (Packaging Engineering): Manages material selection, eco-efficiency research, and building the physical cardboard scale model.
6. Kemal Yilmaz (Electronics - ICT): Handles the smart system hardware, projector integration, and database management.

**Key External Stakeholders** These are the people outside our team who are impacted by our project:

- EPS Supervisors & Teachers: They guide our academic progress and grade our deliverables. We manage their expectations by meeting all deadlines and updating our Wiki logbook.
- Clinic Directors (The Customers): The private dentists and therapists who will buy the Cocoon. We manage them by proving the product is easy to clean and will save their clinic time and money.
- Patients & Parents (The Users): The anxious children and their parents. We manage their needs by ensuring the final pod is safe, calming, and inclusive.

- Local Suppliers: Companies like F. Marques da Silva and Artnovion who provide our materials.

## Communications

Document how your team will manage communications, describing communication channels, meetings, etc.

## Risk

Identify key risks (product and project level), evaluate them and define how they should be handled (responses) and monitored. Perform quantitative and qualitative risk analysis and use the results to define the appropriate risk responses.

## Procurement

Document your procurement management strategy including make vs buy decisions, materials/services to be acquired, sources, costs, timings, etc.

## Project Plan

### 1. Description of the project schedule and its key phases using a Gantt chart

We decided to organize the tasks according to whether they belong to:

- the initiating phase of the project (Figure 1)
- the development phases of the project (Figure 2)
- the deliverables to be submitted (Figure 3)

#### HEALING SPACES

TEAM 6: Anouc, Daniel, Hanna, Julie, Kemal, Ronja

|                           |            |
|---------------------------|------------|
| Beginning of the project: | 2026-02-23 |
| Poster week:              | 1          |

| TASKS  | ASSIGNED TO | ADVANCEMENT | START      | DUE DATE   |
|--|-------------|-------------|------------|------------|
| <b>Global activities/starting of the project</b>                           |             |             |            |            |
| Looking for needs/problems in healthcare/wellbeing                         | All         | 100%        | 2026-02-23 | 2026-02-28 |
| Brainstorming on solutions and make the decision                           | All         | 100%        | 2026-02-28 | 2026-03-10 |
| Background and related work/Bibliography/State of the Art (interim report) | All         | 100%        | 2026-03-01 | 2026-03-15 |

Figure 1: Tasks from the project initiation phase

| Marketing (interim report)  |               |      |            |            |  |
|---|---------------|------|------------|------------|--|
| Market analysis   | Anouc         | 100% | 2026-03-06 | 2026-03-10 |  |
| Business Idea formulation   | All           | 100% | 2026-03-06 | 2026-03-12 |  |
| Business Model  | Ronja, Hanna  | 70%  | 2026-03-05 | 2026-04-01 |  |
| SWOT analysis   | Ronja, Hanna  | 25%  | 2026-03-28 | 2026-04-04 |  |
| Cocoon system design  |               |      |            |            |  |
| Choose the colors   | All           | 80%  | 2026-03-17 | 2026-03-25 |  |
| Analyze and select hygienic/acoustic interior materials                                       | Julie         | 0%   | 2026-03-25 | 2026-03-30 |  |
| Redesign Cocoon layout for wheelchair accessibility   | Ronja         | 50%  | 2026-03-22 | 2026-03-25 |  |
| Draft Detailed System Schematics & Structural Drawings  | Daniel        | 50%  | 2026-03-14 | 2026-03-25 |  |
| Finalize the ergonomic dimensions   | Hanna         | 20%  | 2026-03-22 | 2026-03-25 |  |
| App Design  |               |      |            |            |  |
| Add a database  | Daniel, Kemal | 0%   | 2026-03-30 | 2026-04-22 |  |
| Design UI mockups (including voice-to-text?) (add an interface)                               | Daniel, Kemal | 0%   | 2026-03-30 | 2026-04-22 |  |
| Projector output integration  | Daniel, Kemal | 0%   | 2026-03-30 | 2026-04-22 |  |
| Backend App - develop local controller logic to bridge UI inputs to projector/scent actuators | Daniel, Kemal | 0%   | 2026-03-28 | 2026-04-22 |  |
| Prototype development   |               |      |            |            |  |
| 3D design model   | Anouc         | 30%  | 2026-03-17 | 2026-03-25 |  |
| 3D model video  | Kemal         | 0%   | 2026-04-04 | 2026-04-22 |  |
| Build cardboard scale model   | Julie         | 0%   | 2026-03-24 | 2026-03-25 |  |
| Communications/Advertisement  |               |      |            |            |  |
| Communication tools   | Ronja         | 15%  | 2026-03-18 | 2026-06-13 |  |

Figure 2: Tasks from the development phase

| Wiki/Deliverables   |                      |     |            |            |  |
|---|----------------------|-----|------------|------------|--|
| Interim report and presentation                                 | All                  | 25% | 2026-03-10 | 2026-04-12 |  |
| Upload refined Interim Report                                   | All                  | 0%  | 2026-05-02 | 2026-05-02 |  |
| Flyer   | Anouc                | 80% | 2026-03-18 | 2026-04-12 |  |
| Leaflet   | Anouc                | 0%  | 2026-04-02 | 2026-04-12 |  |
| Eco-efficiency and Measures for Sustainability (interim report) | Julie                | 40% | 2026-03-10 | 2026-04-12 |  |
| Ethical and Deontological Concerns (interim report)             | Julie                | 50% | 2026-03-10 | 2026-04-12 |  |
| List of Materials ( // \, local providers, price..)             | Daniel, Julie        | 30% | 2026-03-10 | 2026-04-29 |  |
| Packaging solution  | Julie                | 0%  | 2026-05-02 | 2026-05-13 |  |
| Functional tests results  | Ronja, Daniel, Kemal | 0%  | 2026-05-13 | 2026-05-27 |  |
| Final report, presentation, paper, poster and manual            | All                  | 0%  | 2026-04-12 | 2026-06-13 |  |

Figure 3: Deliverables and Tasks related to the Wiki

We divided the tasks according to our strengths and areas of expertise, but some compromises had to be made to meet the needs of the project's progress. For example, marketing tasks are primarily managed by Hanna and Ronja, even though their fields of study are unrelated to this topic.

Figure 4 presents the updated Gantt Chart.

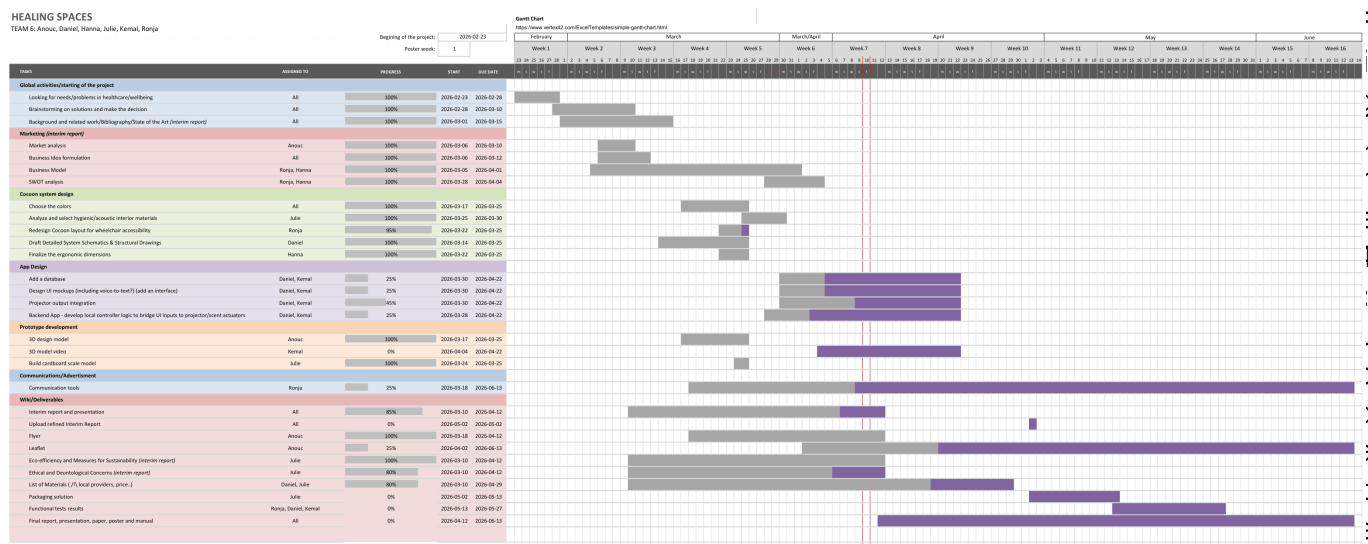

### Gantt Chart

Figure 5 contains the semester schedule (before the last update of the Gantt Chart for the interim report): each purple bar represents the planned time for its completion, with the start and end dates set. The gray area indicates the progress of the task, allowing us to see if we are ahead of schedule or if we still need to do more work on the task.

We observed that the beginning of the project was lengthy in terms of identifying the problem and potential solutions. Indeed, we had several different ideas, and we were only recently able to choose and focus on the final topic of our project. This required a great deal of time for reflection, discussion, and research, some of which were successful, others not. We now have to complete numerous tasks within the same timeframe, some with imminent deadlines; these are the tasks we must focus on first.

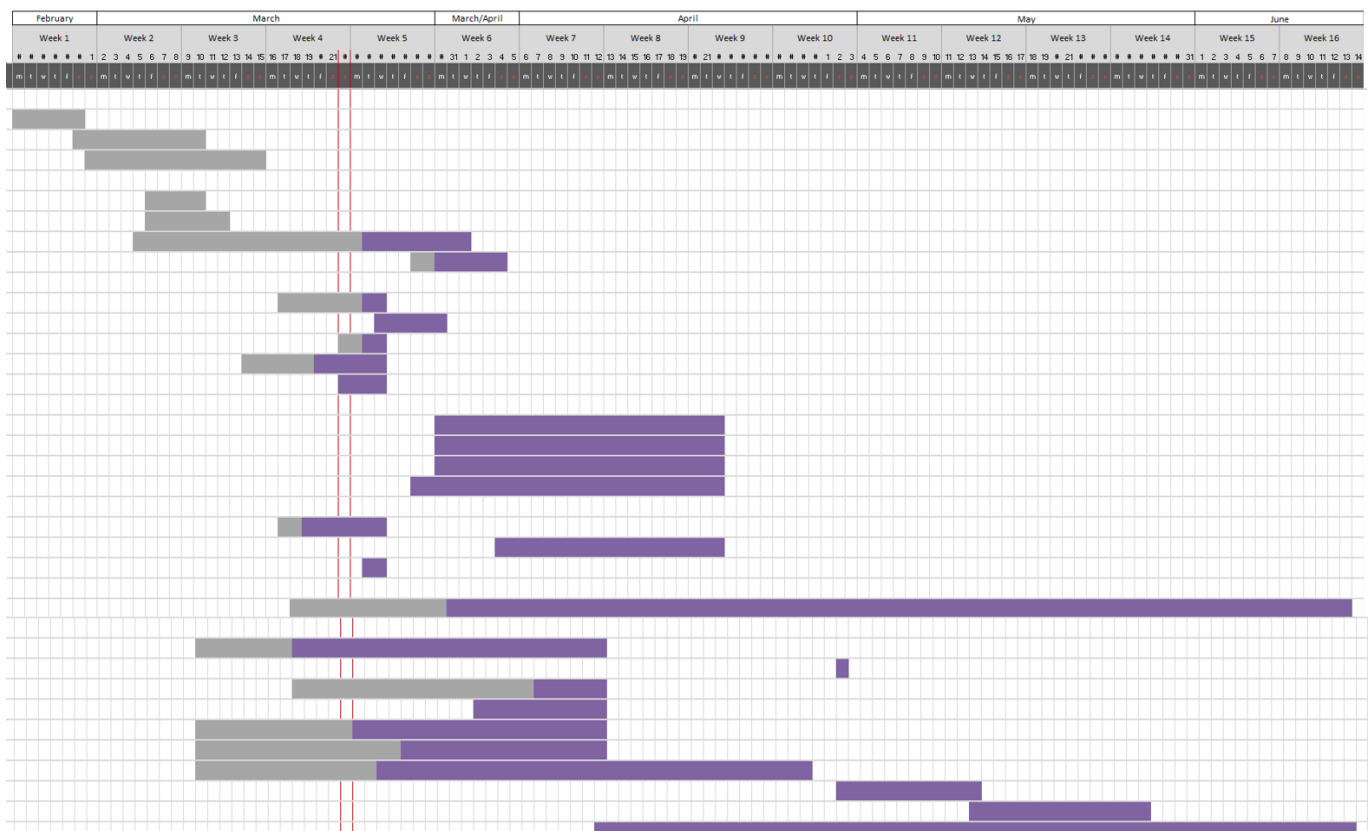

Figure 5: Gantt chart with, for each task, a bar indicating the task completion time (in purple) and its progress (in grey).

## 2. Sprint backlog and sprints created in Planner on Jira:

First of all, discovering and using Jira was not easy. Despite the explanations that we thought we understood, some parameters and steps were not completed successfully on time, notably the timely launch of certain sprints.

Figure 6 is one of the first sprint we organized (but forgot to launch it on time).

Figure 7 is the last sprint we launched, which takes place from April 7th to 14th.

| <input type="checkbox"/> <b>SCRUM Sprint 2</b> 21 Mar – 25 Mar (6 work items) |  | 0 0 0         |             | Start sprint |
|---|--|---------------|-------------|--------------|
| The physical prototype sprint   |  |               |             |              |
| <input type="checkbox"/>  | SCRUM - 39 3D design model                                   | PROTOTYPE ... | IN PROGRESS | Apr 22 0 AG  |
| <input checked="" type="checkbox"/>   | SCRUM - 106 Redesign Cocoon layout for wheelchair acces...   | COCOON SY...  | IN PROGRESS | Mar 25 - KY  |
| <input checked="" type="checkbox"/>   | SCRUM - 107 Finalize the ergonomic dimensions                | COCOON SY...  | IN PROGRESS | Mar 25 - HK  |
| <input checked="" type="checkbox"/>   | SCRUM - 108 Draft Detailed System Schematics & Structural... | COCOON SY...  | IN PROGRESS | Mar 25 - DP  |
| <input checked="" type="checkbox"/>   | SCRUM - 109 Build Cardboard Scale Model                      | PROTOTYPE ... | TO DO       | Mar 25 - JB  |
| <input checked="" type="checkbox"/>   | SCRUM - 110 Improve the flyer after the recieved feedback    | MARKETING     | IN PROGRESS | Mar 25 - AG  |

Figure 6: Scrum Sprint 2

| <input type="checkbox"/> <b>SCRUM Sprint 3</b> 7 Apr – 14 Apr (8 work items) |  | 0 0 0                |             | Complete sprint |
|--|--|----------------------|-------------|-----------------|
| Materials, wiki and preparing the interim presentation                       |  |                      |             |                 |
| <input type="checkbox"/>   | <del>SCRUM - 115</del> Start page                        | DELIVERABLES/WIKI    | DONE        | Apr 1 - DP      |
| <input type="checkbox"/>   | SCRUM - 111 Interim report and presentation              | DELIVERABLES/WIKI    | IN PROGRESS | Apr 12 - RK     |
| <input type="checkbox"/>   | <del>SCRUM - 34</del> Analyze and select hygienic/aco... | COCOON SYSTEM DE...  | DONE        | Mar 30 - JB     |
| <input type="checkbox"/>   | SCRUM - 112 Final List of Materials LOCAL pr...          | DELIVERABLES/WIKI    | IN PROGRESS | Apr 29 - KY     |
| <input checked="" type="checkbox"/>  | <del>SCRUM - 107</del> Finalize the ergonomic dimensi... | COCOON SYSTEM DE...  | DONE        | Apr 1 - HK      |
| <input checked="" type="checkbox"/>  | <del>SCRUM - 106</del> Redesign Cocoon layout for wh...  | COCOON SYSTEM DE...  | DONE        | Apr 1 - KY      |
| <input type="checkbox"/>   | <del>SCRUM - 74</del> Flyer                              | DELIVERABLES/WIKI    | DONE        | Apr 12 - AG     |
| <input checked="" type="checkbox"/>  | <del>SCRUM - 117</del> Detailed Schematics few chang...  | PROTOTYPE DEVELOP... | DONE        | Apr 1 - DP      |

Figure 7: Scrum Sprint 3

Figure 8 is the curent backlog (edited on April 9th) with tasks that still need to be completed.

| <input type="checkbox"/> <b>Backlog</b> (10 work items) |   | 0 13 0               |             | Create sprint |
|---|---|----------------------|-------------|---------------|
| <input type="checkbox"/>                                | SCRUM - 39 3D design model  | PROTOTYPE DEVELOP... | IN PROGRESS | Apr 22 0 AG   |
| <input type="checkbox"/>                                | SCRUM - 40 3D model video   | PROTOTYPE DEVELOP... | TO DO       | Apr 22 - KY   |
| <input type="checkbox"/>                                | SCRUM - 51 Add a database   | APP DESIGN           | IN PROGRESS | Apr 22 - KY   |
| <input type="checkbox"/>                                | SCRUM - 52 Design UI mockups (including voice-to-text?) (add an interface)          | APP DESIGN           | IN PROGRESS | Apr 22 - DP   |
| <input type="checkbox"/>                                | SCRUM - 104 Backend App - develop local controller logic to bridge UI inputs to ... | APP DESIGN           | IN PROGRESS | Apr 22 13 DP  |
| <input type="checkbox"/>                                | SCRUM - 98 Projector output integration   | APP DESIGN           | IN PROGRESS | Apr 22 - DP   |
| <input type="checkbox"/>                                | SCRUM - 60 Ethics and Deontology  | DELIVERABLES/WIKI    | IN PROGRESS | Apr 12 - AG   |
| <input type="checkbox"/>                                | SCRUM - 47 Logbook  | DELIVERABLES/WIKI    | IN PROGRESS | - HK          |
| <input type="checkbox"/>                                | SCRUM - 73 Communication tools  | ADVERTISEMENT        | IN PROGRESS | - RK          |
| <input type="checkbox"/>                                | SCRUM - 75 Leaflet  | DELIVERABLES/WIKI    | IN PROGRESS | Jun 13 - AG   |

Figure 8: Last backlog edited on April 9th

Finally, 9 is the Jira planner in which we created the Epics, Stories, and corresponding tasks.

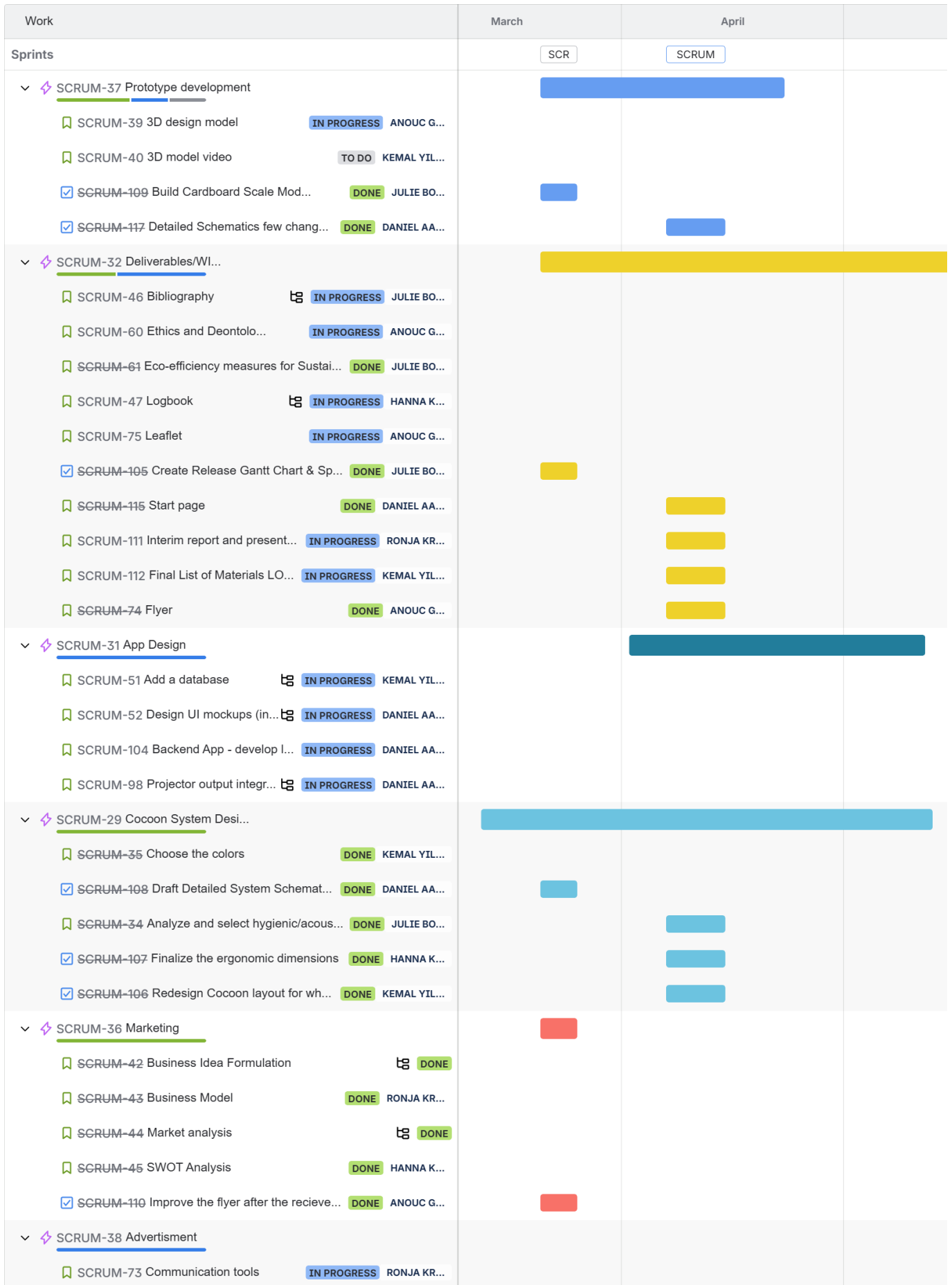

Figure 9: Jira Planner

### 3. Prioritization, estimation process and underlying challenges

We tried to prioritize tasks based on the deadlines and deliverables to respect, but it was also based on our estimated workload and the time it would take.

The tricky part was finding compromises based on each person's areas of expertise and the time the tasks could take.

*Provide a summary of the sprints that were executed, along with sprint goals.*

## Sprint Outcomes

*Include the outcomes of all sprint reviews (what was the sprint backlog, completion status, planned capacity vs. achieved velocity).*

## Sprint Evaluations

*Include the summary of all the sprint retrospectives, including any actions implemented as part of the team's continuous improvement strategy.*

## Summary

*Provide here the conclusions of this chapter and make the bridge to the next chapter.*

2026/02/16 21:07 · epsatisep · [0 Comments](#)

# Marketing Plan

## Introduction

*Provide here an overview of the contents (structure) of this chapter.*

For **European Project Semester 2026** our team is developing an idea in the Smart Health and Wellbeing domain. We want to introduce **Healing Cocoon** – a virtual reality cocoon for waiting rooms and other clinical spaces. Designed for children with stress and anxiety problems related to medical procedures. This marketing plan supports our technical work by proving the product's business value (crucial for commercialization of our idea). It is essential for showing that our solution solves a real market problem, is financially realistic, and can be effectively sold to pediatric healthcare facilities.

## Business Idea Formulation

Healing Cocoon is an interactive, wheelchair-accessible cocoon equipped with a short-throw projector that transports pediatric patients to a calming, magical fantasy world during dentist, therapy visits.

### Core Features:

- Immersive, projection of animated, child-friendly fantasy worlds or similar surroundings.
- Interactive depth sensors that allow children to safely interact with the projections.
- Calming scents (e.g., lavender, sweet orange) and soft spatial audio.

### Customer Needs Met:

- For the End-User (Patients & Parents): Provides emotional comfort, actively distracts from clinical environments, and significantly reduces acute fear and stress before medical treatments.
- For the Buyer (Clinics & Hospitals): Transforms a standard waiting room into a premium, family-friendly experience. By calming the child beforehand, it reduces appointment delays, improves patient cooperation during examinations, and builds brand loyalty for the practice.

## Business Model

Using the Value, Velocity, Visibility, Verifiability, Virtuality, Vulnerability (6-V) Value Exchange framework [20], here is how value flows between the key actors in our targeted private clinic market:

- The Company (HealingCocoon): We create value by designing and manufacturing the physical Cocoon pods and developing an expanding software library of evidence-based sensory content (visuals, sounds, scents). In exchange, we capture value through a Business-to-Business (B2B) revenue model consisting of a direct sales/installation fee, followed by a recurring monthly subscription for software updates and fresh content carousels.
- The Customers (Pediatric Dental, Psychiatric, and Therapy Clinics): Clinic owners exchange financial capital to purchase the Cocoon. In return, they receive a cutting-edge waiting room solution that acts as a strong competitive differentiator. Furthermore, by pre-calming anxious children, clinics reduce appointment delays caused by patient distress, directly increasing their operational efficiency and patient throughput.
- The Consumers (Pediatric Patients & Parents): Patients and parents invest their time in the clinic's waiting area. Instead of exchanging that time for mounting stress, dental anxiety, or sensory overload, the Cocoon provides them with a safe, regulated environment, emotional comfort, and a positive association with their healthcare visits.
- Collaborators: We exchange value with hardware manufacturers (for short-throw projectors, audio systems, and hygienic materials), software developers, and crucial psychological/pediatric advisors who help us design evidence-based calming environments. Additionally, we collaborate with medical interior fit-out companies to seamlessly integrate the Cocoons into existing private practice floor plans.

## Market Analysis

To ensure the commercial viability of the HealingSpaces Cocoon, it is essential to analyze the external forces that influence our market success. Following a thorough risk analysis regarding infection control and cross-contamination, we strategically narrowed our target market from general pediatric hospitals to specialized private practices—specifically pediatric dental, psychiatric, and therapeutic clinics. These environments experience high patient anxiety but carry a significantly lower risk of contagious disease transmission.

The micro-environment consists of actors close to the company that affect our ability to serve our customers:

- **Customers (Business Market):** Our primary B2B buyers are private pediatric dental offices and child psychology/occupational therapy centers. These clinics seek competitive differentiation and higher operational efficiency by preventing appointment delays caused by distressed children.
- **Competitors:** Direct competitors include traditional waiting room entertainment, e.g., generic TVs, wall-mounted bead mazes, and emerging tech like VR headsets. The Cocoon holds a strategic advantage over VR by eliminating the need for wearable devices, easing hygiene maintenance between patients, and preventing total social isolation.
- **Suppliers & Intermediaries:** Our supply chain relies on manufacturers of short-throw projectors, depth sensors, and medical-grade, easily sanitizable textiles. We will also partner with healthcare interior design firms as intermediaries to facilitate clinic installations.

The macro-environment consists of larger societal forces that shape our business opportunities:

- **Demographic & Cultural Forces:** There is a growing societal awareness of neurodiversity, e.g., Autism, Attention-Deficit/Hyperactivity Disorder (ADHD), and a strong cultural push by parents to prevent “medical trauma.” Modern parents actively seek out healthcare facilities that prioritize a child’s emotional and sensory safety.
- **Economic Forces:** While public healthcare systems face strict budget constraints, private dental and therapy practices operate in a highly competitive economic landscape. They are willing to invest capital into premium waiting room experiences to attract and retain higher-paying clients.
- **Political & Legal Forces:** By pivoting away from standard hospital waiting rooms, we bypass the strictest medical device and contagious disease regulations. However, the product must still comply with standard fire safety codes, ADA/wheelchair accessibility standards, and basic clinical sanitation requirements.
- **Technological Forces:** The increasing affordability and miniaturization of short-throw projectors, IoT sensors, and directional audio make the production of a smart, interactive cocoon financially and technically feasible today.

## SWOT Analysis

The SWOT analysis in Figure 10 reveals that while the Healing Cocoon requires a significant physical footprint and upfront capital investment from clinics (Weaknesses), its ability to increase daily operational efficiency and provide a superior, hygienic experience (Strengths) justifies the cost. Externally, competing against cheaper digital distractions like tablets, alongside potential clinic budget freezes, poses realistic challenges (Threats). However, our strategic pivot to specialized pediatric dentistry and therapy centers perfectly aligns with the surging demand for neurodivergent-friendly healthcare (Opportunities). Overall, by targeting high-anxiety, low-infection environments, we minimize our primary risks and establish a highly defensible B2B market position.

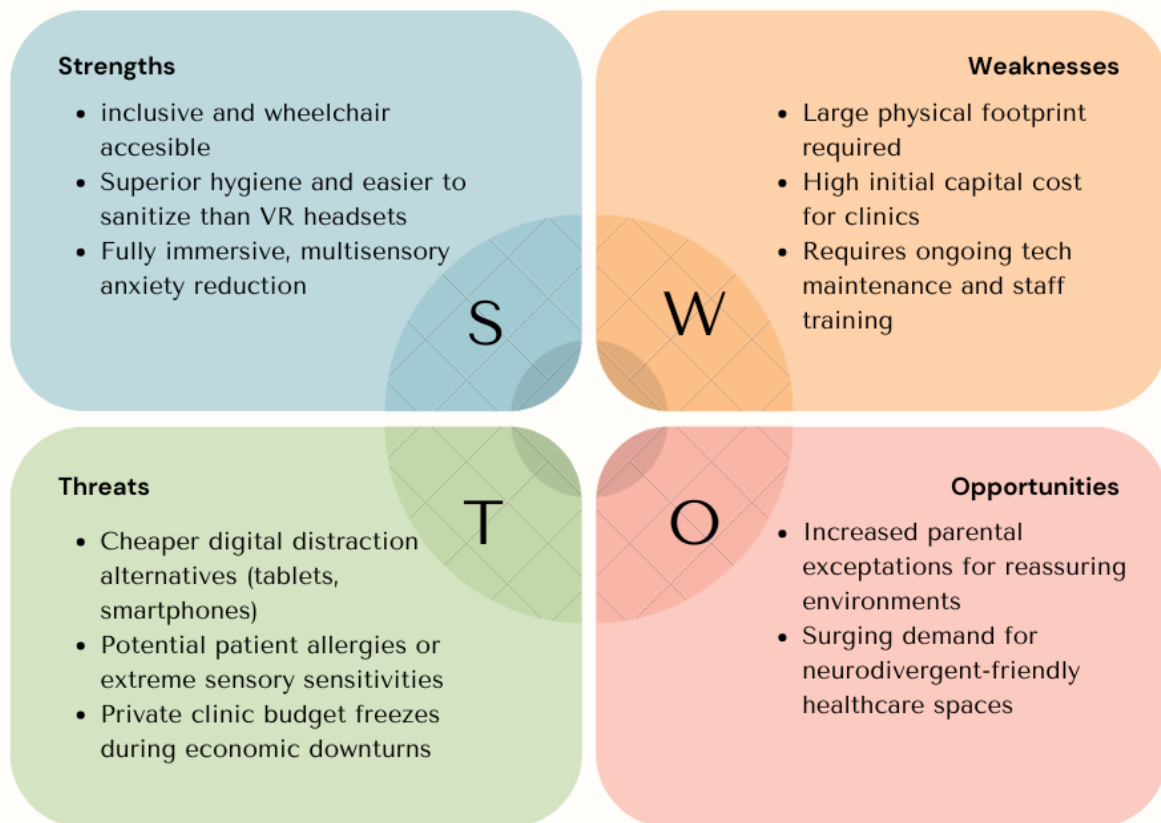

Figure 10: SWOT analysis diagram for Healing Cocoon project

## Strategy

### Strategic Objectives

The primary strategic goal is to establish the HealingSpaces Cocoon as the premier, non-pharmacological anxiety-reduction tool for specialized pediatric care—specifically private pediatric dentistry and child therapy centers. Because we are a Business-to-Business (B2B) company, our sales targets focus on clinical adoption rather than mass consumer volume. Our measurable objectives are:

- Year 1: Secure 5 to 10 pilot installations in local private clinics to gather clinical case studies and testimonials.
- Year 3: Establish the Cocoon as a standard architectural feature in high-end, newly renovated pediatric clinics, achieving 50+ active installations regionally.

### Segmentation and Targeting

Because the Cocoon operates more specifically on a Business-to-Business-to-Consumer (B2B2C) model, our targeting strategy must address two distinct groups: the clinics that purchase the product and the patients who use it.

## 1. The Customers (The Buyers):

Specialized private practices, such as pediatric dentistry and therapy clinics. They exchange financial capital for a cutting-edge solution that provides a competitive advantage, improves patient satisfaction, and prevents costly appointment delays caused by distressed children.

### 1. The Consumers (The End-Users):

The pediatric patients and their parents who invest their time in the waiting room. To clearly illustrate the emotional and physical needs of our target audience, we developed two primary user personas:

- **Persona 1 (The Dental Patient):** A 9-year-old girl waiting in a dentist's office. She is emotional, sensitive, and easily scared by clinical or medical environments. She actively avoids sensory overload and requires a calm, positive, and safe space to regulate her emotions before sitting in the dental chair.
- **Persona 2 (The Therapy Patient):** An 11-year-old boy in a wheelchair waiting to see a therapist. He often feels frustrated and anxious about his upcoming sessions. He needs to be comfortably accommodated without leaving his wheelchair, and he requires engaging, accessible entertainment to distract him and focus his mind on something other than the appointment.

By focusing our B2B sales efforts on the Buyers (the clinics), we directly solve the acute stress and accessibility needs of our Consumers (these patient personas). Our rollout strategy to acquire these clinics is as follows:

- **Short term (0-12 months):** Target 5 to 10 early-adopter pediatric dental and therapy practices in the local urban area to launch pilot programs and gather clinical case studies.
- **Medium term (1-3 years):** Expand market share by acquiring 50+ specialized private practices nationwide, leveraging our pilot testimonials.
- **Long term (3-5 years):** Establish the Cocoon as standard equipment for child-friendly practices through licensing or collaborations with major medical furniture suppliers.

## Positioning

Our positioning strategy bridges the gap between delivering a premium emotional experience for our consumers (patients and parents) and providing a tangible return on investment for our customers (the clinics).

**Unique Selling Proposition (USP):** The HealingSpaces Cocoon is the only fully wheelchair-accessible, multisensory waiting room environment that actively transforms pre-appointment anxiety into a calming, immersive experience—preventing emotional meltdowns and saving specialized clinics from costly scheduling delays.

### Positioning in the Market:

To achieve a competitive advantage, the Cocoon is positioned in the minds of our target customers based on two key dimensions:

Identification:

We establish the Cocoon within the category of premium, medical-grade waiting room equipment. Like high-end clinic furniture, it meets strict hygiene, safety, and ADA/accessibility standards.

## Differentiation:

- Versus Traditional Distractions (Toys/Tablets). Instead of passive, isolated digital distraction, the Cocoon offers “active immersion.” It regulates the sensory environment (visuals, sounds, calming scents) to actively soothe emotional patients (like our 9-year-old persona).
- Versus Wearable Tech (VR Headsets) - While VR offers high immersion, it is socially isolating, causes hygiene concerns, and is often incompatible with young or highly sensitive children. The Cocoon delivers a shared, highly hygienic 180-degree experience.
- Unlike fixed play structures, the Cocoon's physical footprint is explicitly designed for barrier-free entry, ensuring patients in wheelchairs (like our 11-year-old persona) can independently enjoy the full experience without frustration.

## Marketing-Mix

To successfully implement our strategy and deliver our Unique Selling Proposition to specialized private clinics, we have aligned the traditional 4Ps with the customer-centric 4Cs framework:

### Product & Customer Value

**Product:** The HealingSpaces Cocoon is a multi-sensory, semi-enclosed relaxation pod. It features a 180-degree short-throw projector, spatial audio, and an integrated scent system. The physical design is barrier-free and 100% wheelchair accessible, ensuring inclusivity.

**Customer Value:** For the clinic, it provides a functional competitive advantage by preventing appointment delays caused by distressed children. For the consumers (like our personas - the highly sensitive 9-year-old girl and the 11-year-old boy in a wheelchair), it offers emotional safety, distraction, and a fear-free waiting experience.

### Price & Cost

- Price (The Revenue Model): We utilize a premium, two-tiered “razor and blades” pricing strategy.

*Upfront Hardware:* A one-time purchase price of 2000 €–2500 € for the physical pod and installation.

*Recurring Subscription:* A monthly fee of 9.99 €–19.99 € for software updates, new interactive environments, and fresh scent cartridges.

- Cost (The Customer's Investment): From the clinic's perspective, the “cost” includes the financial purchase and ongoing maintenance. However, this is heavily offset by the perceived ROI (Return on Investment): higher patient throughput, better online reviews from relieved parents, and increased patient loyalty.

### Place & Convenience

- Place (Distribution): Sales are strictly B2B. We target private pediatric dental practices, child psychology clinics, and occupational therapy centers. Distribution is handled via direct sales and strategic partnerships with medical interior design firms and healthcare equipment suppliers.
- Convenience (Ease of Use): The Cocoon is designed for seamless integration into existing waiting rooms with a highly efficient footprint (165cm x 110cm). It is “plug-and-play” and self-explanatory for children to use. Crucially, the smooth, projector-based interior is incredibly

convenient for clinic staff to sanitize quickly between patients.

## Promotion & Communication

- Promotion (The Tactics): Our primary B2B marketing channels include presentations at dental and therapeutic trade fairs, highly targeted LinkedIn/online marketing aimed at clinic directors, and leveraging video testimonials from our local pilot installations.
- Communication (The Dialogue): Our core message to clinics is: “Transform your waiting room into a calm, efficient, and inclusive experience.” Communication will focus on building clinical trust by highlighting the evidence-based emotional impact on children and the operational stress reduction for medical staff.

## Brand

The name of the product is Healing Cocoon. We chose this name because it represents the idea of creating a safe and calming space where children can relax and feel protected. The concept is inspired by a cocoon, where a caterpillar transforms into a butterfly. In the same way, children enter the cocoon feeling anxious or stressed, and leave feeling calmer and more at ease.

## Logo



The logo is based on the idea of a cocoon and a butterfly combined into one shape. It represents both protection and transformation. The soft and flowing lines give a feeling of calmness and safety, while the butterfly shape symbolizes freedom and positive change.

In the center, there is a small star-like shape which represents a moment of relief or comfort. This reflects the main goal of the product, which is to reduce anxiety and create a more positive experience.

## Color Palette

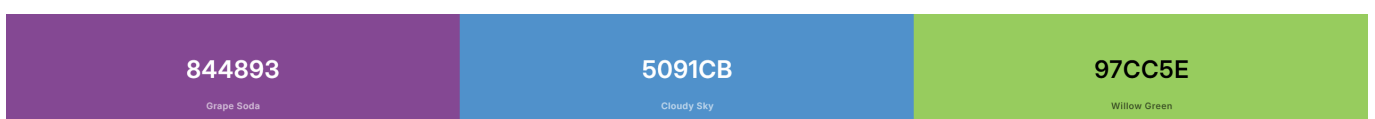

The color palette is based on calm and soft colors that support relaxation.

Green represents healing and nature. Blue represents trust and calmness. Purple represents imagination and emotional comfort.

The colors are often used in gradients, which helps create a smooth and soft transition between them. This also reflects the idea of going from stress to relaxation.

## Marketing Programmes

### Programmes

To successfully implement our B2B go-to-market strategy, we have defined four specific, actionable promotional programs:

1. **Direct Sales:** Addressing private medical and dental practices via presentations at industry trade fairs, dental congresses, and targeted B2B mailing lists.
2. **Online store & Website:** Developing a professional digital presence to host product information, 3D renders, clinical testimonials, and an easy B2B ordering portal.
3. **B2B Collaborations:** Establishing strategic distribution partnerships with established medical practice equipment shops and healthcare furniture suppliers.
4. **Pilot Programs:** Deploying free test installations in selected local practices (e.g., pediatric dentists) to collect clinical experience reports, usage data, and video testimonials.

### Budget

The Healing Cocoon is positioned as a high-end experience for children. Our financial returns are driven by a “razor and blades” revenue model:

1. One-time purchase: 2000 € - 2500 € for the physical hardware setup (including the pod, projector, spatial audio, and initial scent cartridges).
2. Subscription model: 9.99 € - 19.99 € per month for ongoing software updates, new digital projection environments, and fresh fragrance carousels.

### Control

To ensure our marketing efforts yield a positive Return on Marketing Investment (ROMI), we will monitor the following Key Performance Indicators (KPIs):

1. Sales figures: Tracking the number of Cocoon systems sold and analyzing quarter-over-quarter sales growth.
2. Customer satisfaction: Conducting short surveys with clinic staff and parents to evaluate their stress reduction, alongside feedback from doctors.
3. Cocoon usage metrics: Observing the frequency of use in the waiting room and analyzing software data to determine the most popular projection environments and sounds.
4. Marketing performance: Tracking website analytics, B2B lead generation (inquiries from practices), and evaluating the success rate of trade fair contacts.
5. Economic control: Continuously comparing marketing expenditure against generated revenue to calculate overall ROMI.

## Summary

Our preliminary marketing analysis suggests that the Healing Cocoon has strong potential to be a viable project based on our Optimal Value Proposition. If our upcoming pilot phase is successful, we anticipate the Cocoon will provide a fear-free experience for the consumer (child and parent), help mitigate costly scheduling delays for the customer (the clinic), and establish a foundation for a recurring revenue stream for the company.

Based on this market and economic analysis, the team decided to create a wheelchair-accessible, multi-sensory waiting room pod intended for private pediatric dentistry and child therapy clinics. We targeted this specific market niche because these environments experience high daily patient anxiety and have a surging demand for neurodivergent-friendly spaces, yet they avoid the strict cross-contamination regulatory barriers found in general hospitals, allowing for faster B2B adoption and high ROI.

Consequently, the team decided to design a solution with the following features added specifically for market reasons: a highly hygienic, wipeable hard-shell interior (as a market advantage over hard-to-clean VR headsets), strict physical dimensions to fit standard clinic waiting rooms, a barrier-free entryway for inclusivity, and a “razor and blades” subscription model for software and scent cartridges to ensure long-term profitability.

While the economic viability of the Healing Cocoon is clear, producing a premium hardware device requires physical manufacturing, electronic components, and material sourcing. To ensure our product is not only economically viable but also environmentally responsible, the next chapter will detail the Eco-efficiency Measures for Sustainability integrated into our structural design and product lifecycle planning.

2026/02/16 21:08 · epsatisep · [0 Comments](#)

## Eco-efficiency Measures for Sustainability

Eco-efficiency is defined as the delivery of cost-effective products and services that meet human needs and improve quality of life, while progressively reducing ecological impacts and resource use throughout their life cycle, aligning with the earth's carrying capacity. It emphasizes efficient use of materials and energy to achieve profitability and value addition.

### Introduction

First of all, eco-efficiency is about designing products that reduce environmental impact while still meeting people's needs. In this project, the cocoon is designed to help reduce children's anxiety in waiting rooms through calming scents, visuals, and sounds, while also being accessible (including wheelchair access) and hygienic

Because this is a healthcare-related environment, sustainability is not only about the environment but also about well-being and safety. Research [\[21\]](#) shows that the design of spaces, including sound, light, and sensory elements, can have a strong impact on stress and anxiety levels, especially in children.

## Environmental

From an environmental point of view, the main focus is on the materials used and their impact. There are several aspects about it:

- Recycling
- Reducing
- Re-using

When it comes to the product, it is essential to limit its harmful impact on the environment. This can be done by cutting down, reusing, and recycling raw materials, considering energy use throughout every stage of the project, and reducing transportation as much as possible.

Regarding our project: The cocoon uses aluminium and brass, which are good choices in terms of sustainability because they are very durable and highly recyclable. Aluminium, especially, can be recycled many times without losing quality, which fits well with circular design principles.

However, materials like acoustic foam can be problematic because they are often made from petroleum-based products and can release harmful emissions (like VOCs). According to studies [22] and [23], more sustainable alternatives include recycled textile-based acoustic panels or PET felt, which can achieve similar acoustic performance with lower environmental impact.

The antimicrobial technical textile is important for hygiene, but it's also important to make sure it has low chemical emissions and is safe for indoor air quality, especially since children are more sensitive to pollutants.

Another important aspect of the project's sustainability is the decision to work with Portuguese suppliers. By sourcing materials locally, the environmental impact related to transportation can be reduced, especially in terms of CO<sub>2</sub> emissions from long-distance shipping. Research in sustainable supply chains [24] shows that transport distance is directly linked to carbon emissions, and reducing this distance is an effective way to lower the overall environmental impact of a product.

In addition, transportation is a major contributor to global greenhouse gas emissions, with the transport sector accounting for a significant share of energy-related emissions [25].

By working with local suppliers, the project can therefore reduce transport distances and associated emissions. At the same time, this approach supports the local economy, allows for shorter delivery times, and improves communication and quality control. For this project, materials such as aluminium, technical textiles, and acoustic solutions should, whenever possible, be sourced from suppliers based in Portugal.

## Economical

The economic aspect of sustainability focuses on creating long-term economic growth, profitability, and stability without harming environmental or social systems. It ensures businesses remain viable while operating ethically, using resources efficiently, and fostering innovation.

This aspect can be an issue because it is often the most challenging, as it is closely tied to political perspectives, influencing views on what is considered economically viable, as well as the potential

impact on businesses, employment, and job opportunities.

It is important to offer incentives that motivate companies to go beyond legal requirements and follow sustainable practices. At the same time, individuals should be encouraged to contribute in whatever ways they can, whenever possible.

## Social

The social aspect is actually one of the most important parts of this project.

The cocoon is designed to create a safe and calming space for children, helping to reduce anxiety while they wait.

Accessibility is also key. By including wheelchair access, the design becomes more inclusive and usable for a wider range of children, which is an important part of sustainable design.

The use of non-toxic and antimicrobial materials also improves safety, especially for children who may be more vulnerable to infections or poor air quality.

Additionally, reducing noise and stress doesn't just help patients—it can also improve the experience for parents and healthcare staff, making the whole environment more comfortable.

## Life Cycle Analysis

Looking at the full life cycle of the cocoon helps understand its overall impact.

Here are the different phases:

- **Materials:** Aluminium and brass require a lot of energy to produce, but they can be recycled, which reduces long-term impact. Textiles and acoustic materials could be improved by using recycled or bio-based options.
- **Production:** The cocoon is designed with a structure using aluminium bows and brass panels. Prefabricated parts reduce manufacturing waste and energy use, and assembling the cocoon on-site is more efficient than building it from scratch. Choosing low-energy manufacturing processes for metal bending, panel cutting, and textile finishing can also make a difference.
- **Transport:** Transporting materials can contribute significantly to the product's carbon footprint, especially for heavy or bulky items like brass panels or acoustic boards. By sourcing materials from Portuguese suppliers (F. Marques da Silva S.A. [26], [27], Artnovion [28], Monteiro Fabrics [29]), we can reduce transport distances, which lowers CO<sub>2</sub> emissions, shortens delivery times, and simplifies logistics. Using local suppliers also supports the local economy and makes communication and quality control easier.
- **Use:** The cocoon is designed to last a long time, thanks to durable metals and textiles. Low maintenance requirements (especially with antimicrobial textiles) reduce environmental and economic costs during use. Additionally, by providing calming sounds and visuals, the cocoon helps reduce stress in children, which is a social benefit not usually quantified in LCA but is an important part of its life-cycle value.
- **End-of-life:** The design allows for disassembly and recycling. Aluminium and brass can be fully recycled, while textiles and acoustic materials could be reused or repurposed if chosen carefully. Designing for end-of-life reduces waste and supports circular economy principles.

Choosing more recyclable or bio-based materials further improves sustainability.

## Summary

The LCA shows that the main impacts are in material production and transportation, while the use and end-of-life phases have lower environmental burdens if the materials are durable and recyclable. By choosing local suppliers, modular construction, and sustainable materials, the cocoon project maximizes eco-efficiency while still being functional, safe, and calming for children.

2026/02/16 21:09 · epsatisep · [0 Comments](#)

# Ethical and Deontological Concerns

## Introduction

Ethics plays a central role in engineering design, ensuring that technological solutions contribute positively to society while avoiding harm. In a context where technological developments and professional responsibilities are constantly evolving, ethical and deontological issues have become essential in guiding decision-making and professional conduct. Beyond technical skills, engineers are expected to act in accordance with moral principles, legal frameworks, and the broader interests of society.

This is especially important in healthcare environments, where user safety, well-being, and trust are critical. This chapter examines the ethical and deontological aspects of the multisensory cocoon concept, designed to improve patient experience through immersive projection technology.

The analysis is based on engineering ethics principles and sustainable development frameworks. Key topics include engineering ethics, ethical considerations in sales and communication, environmental responsibility, and liability. Special attention is given to user well-being, sustainability, accessibility, and safety. Finally, this chapter also connects ethical considerations to the Life Cycle Assessment (LCA) and Design for Sustainability (D4S) approach used in the project.

## Engineering Ethics

Engineering ethics is part of business and corporate ethics and focuses on the responsibilities of engineers toward society, the profession, and stakeholders. Engineers must ensure that their work contributes positively to people and the environment, while minimizing risks and harm.

According to principles of sustainable engineering, engineers must aim to maximize positive impact and minimize negative impact on both people and the environment. This is especially relevant in healthcare-related projects, where user safety and well-being are critical.

For this project, the following ethical duties are particularly relevant:

- Duties to the profession: The team must ensure that the design is safe, reliable, and based on

sound engineering principles. The system should not create additional risks for patients or healthcare staff.

- Duties to the community: The solution aims to improve patient well-being by reducing stress and anxiety. This aligns with the ethical responsibility to contribute positively to society.
- Duties to the employer/client: The design must be feasible, realistic, and aligned with healthcare needs and constraints. It should provide real value and not just a conceptual benefit.
- Duties to colleagues: The project requires collaboration across disciplines (design, healthcare, technology). Ethical behavior includes clear communication, respect, and shared responsibility.

## Sales and Marketing Ethics

The marketing approach for the multisensory cocoon concept is based on ethical principles of honesty, transparency, and responsibility. As the system is designed to improve patient well-being, it is essential to communicate its benefits without exaggeration or misleading claims.

While immersive environments have been shown to reduce stress and anxiety, it would be unethical to present the solution as a guaranteed medical outcome without sufficient scientific evidence. Therefore, the concept is positioned as a supportive tool that enhances the patient experience, rather than a replacement for medical treatment.

The communication strategy focuses on clearly presenting both the strengths and limitations of the system. By providing accurate and realistic information, the design builds trust between designers, healthcare professionals, and patients. This approach ensures that expectations remain aligned with the actual capabilities of the product, while maintaining ethical integrity in a healthcare context.

## Environmental Ethics

Environmental responsibility plays a key role in the development of the multisensory cocoon concept. In line with principles of sustainable engineering, the design aims to balance environmental, social, and economic aspects throughout the product's life cycle.

A major environmental consideration within this project is energy consumption. The system relies on components such as projectors, sensors, and potentially a small HVAC system, which together contribute to the overall environmental impact during the use phase. Based on the Life Cycle Assessment (LCA), this phase represents the most significant environmental burden. Therefore, reducing energy consumption is a primary design focus, for example by selecting energy-efficient components and minimizing unnecessary system activity.

Material selection is another important aspect of environmental ethics. The cocoon structure is primarily based on materials such as aluminum, which is durable and recyclable, combined with functional materials like technical PVC and foam. While some of these materials have environmental drawbacks, they are chosen for their performance and longevity. By prioritizing durability, the design reduces the need for frequent replacement and therefore minimizes waste over time.

In addition, the project considers the end-of-life phase of the product. The cocoon is designed with disassembly in mind, allowing different materials and components to be separated and recycled more easily. This approach helps to reduce electronic waste and supports a more circular use of resources.

Overall, the environmental strategy of the project follows a life-cycle approach (“cradle-to-grave”), ensuring that environmental impact is considered at every stage of the design. By combining energy efficiency, responsible material selection, and end-of-life considerations, the cocoon concept contributes to a more sustainable and ethically responsible healthcare solution.

## Liability

Liability refers to the responsibility engineers have for the safety, reliability, and legal compliance of their product. In healthcare-related applications, this responsibility is especially important, as failures can directly impact patient safety and well-being.

For the multisensory cocoon concept, several potential risks must be carefully considered. These include electrical hazards related to components such as projectors, sensors, and wiring, as well as fire risks associated with electronic systems in a semi-enclosed environment. In addition, physical safety plays a key role, as the structure must remain stable and accessible for all users, including patients with reduced mobility.

To minimize these risks, the design follows established safety principles and regulations. Electrical components are intended to operate at low voltage where possible and must be safely enclosed to prevent user contact. The structural design is developed to ensure stability and safe use, while also allowing easy and secure access. Clear instructions for use and maintenance are necessary to prevent misuse and ensure correct operation.

Compliance with relevant European regulations is essential to ensure legal safety and product reliability. These include directives such as the Machinery Directive, Low Voltage Directive (LVD), EMC Directive, and RoHS Directive. By adhering to these standards, the product can meet the requirements for CE marking and be safely implemented in healthcare environments.

Failure to address these safety and regulatory aspects could result in harm to patients, damage to property, and legal consequences. Therefore, liability considerations play a crucial role in guiding the design toward a safe, reliable, and responsible solution.

## Summary

The multisensory cocoon concept integrates ethical, environmental, and legal considerations throughout the design process. The project focuses on improving patient well-being by creating a safe, non-invasive, and supportive environment.

Environmental responsibility is addressed through a life-cycle approach, with attention to energy consumption, material use, and end-of-life. Insights from the LCA led to a focus on energy efficiency, supported by Design for Sustainability (D4S) strategies.

Marketing is based on transparency, presenting the cocoon as a supportive tool rather than a medical solution. In addition, the design considers relevant EU directives to ensure safety and compliance.

Overall, the project demonstrates how technology can be designed responsibly by balancing user needs, environmental impact, and legal requirements.

The following chapter presents the project development and final design.

2026/02/16 21:10 · epsatissep · [0 Comments](#)

# Project Development

## Introduction

*Provide here an overview of the contents (structure) of this chapter.*

This chapter contains our project's evolution, in particular, you can find currently the concept, designs, smart system, structure and also the materials chosen for the Healing Cocoon.

## Ideation

The idea of the *Healing Cocoon* came to us after reflection and several brainstorming sessions. First, we tried to recall events we had experienced and heard about in the fields of health and well-being. We quickly focused on the impact of the medical environment (hospitals or waiting rooms) and agreed to work on a solution to improve experiences in medical settings.

## Concept

The concept of the *Healing Cocoon* is to transform clinical environments into calming and immersive spaces.

By combining light, sound and scent, it helps reduce stress and improve children well-being.

The features of our *Healing Cocoon*:

- Calming audio and scent stimulation
- Immersive 180° visual environment
- Accessibility for children in wheelchairs

## Design

### Structure

- Initial structural drafts and materials details – Figure [11](#) shows the rigid metal structure made of aluminium arches (this material was chosen because it is less expensive than brass and easy to work with.). In red, we drew the brass panels that will be attached to the metal structure (the exterior surface of the panels will be brushed to make the outside of the cocoon less metallic and more welcoming).

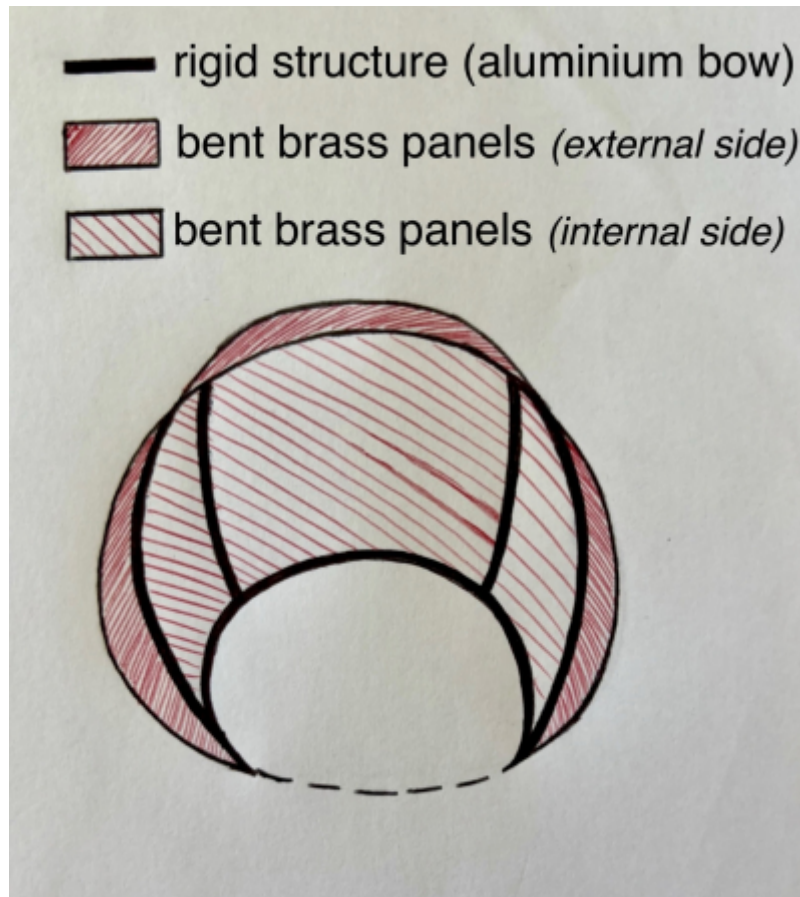

Figure 11: Metallic structure and external part of the cocoon with corresponding materials

Figure 12 shows the internal part and the materials: first, the acoustic panels are fixed using the aluminum structure. Then, the antimicrobial fabric is attached to these panels (using adhesive or the self-adhesive properties of the acoustic panels).

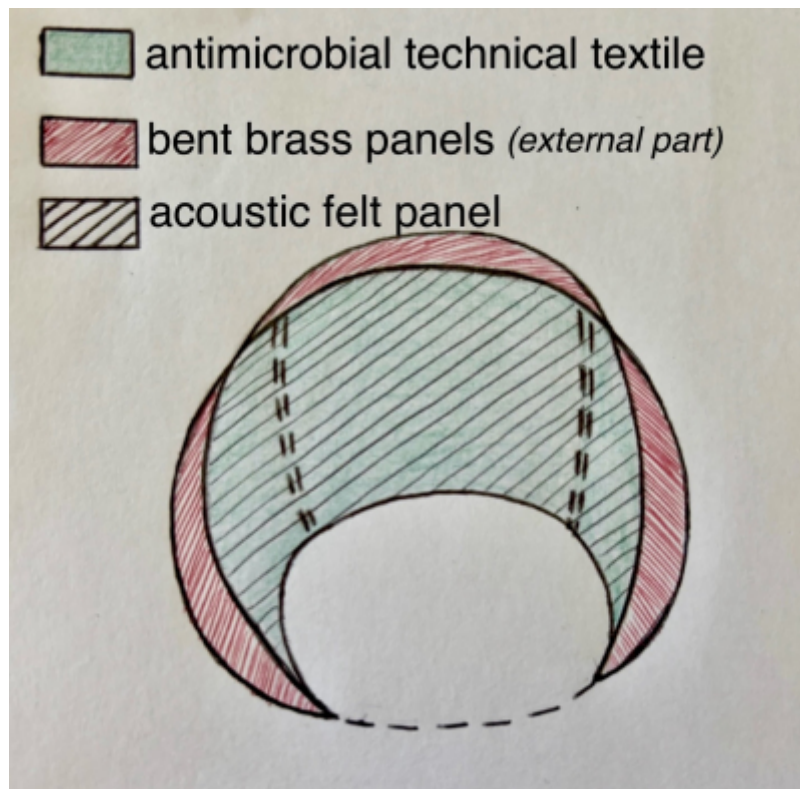

Figure 12: Internal part of the cocoon with corresponding materials

- Material selection - Figure 13 shows the different layers of our cocoon's structure. The air gap is

due to the presence of the arched metallic structure in certain area of the cocoon, as shown in Figure 11. We have compiled a list of Portuguese suppliers who could meet our needs: (i) F.Marques da Silva S.A for the brass panels [30] and the aluminum structure [31]; and (ii) artnovion for the acoustic panels [32]. We are still thinking about the antimicrobial textil we want to use, but Monteiro Fabrics with its MEDIFLEX collection offers interesting possibilities [33]

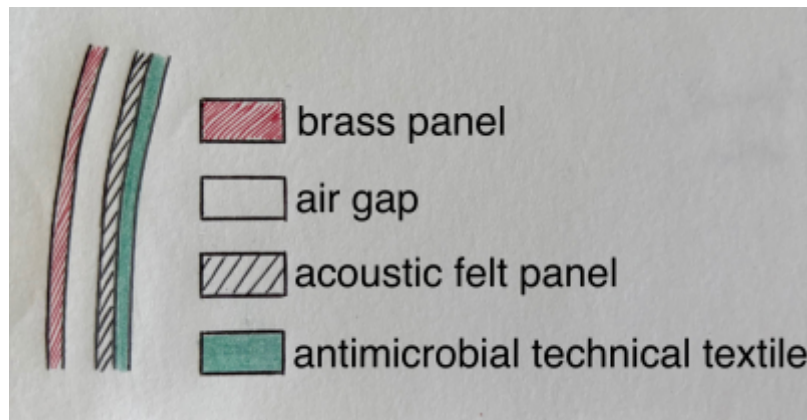

Figure 13: Cross-section of the cocoon's structure and details of materials

- Detailed drawings - Figure 14 shows the evolution of the design of our idea. First of all, we decided that the cocoon will not be fully closed in order to avoid feelings of claustrophobia, but also so that parents could maintain contact with their child if needed. To allow for true sensory immersion, we wanted to incorporate a chair that could vary its positions (sitting, lying down) and rotate to face the visuals. We also wanted the inside of the cocoon to be accessible for children with reduced mobility, such as those in wheelchairs. We are now thinking about adding small wheels to the chair so it can be easily moved when a child in a wheelchair wants to get into the cocoon. These small wheels can be locked once the chair is inside the cocoon.

# HealingSpaces Cocoon Chair - Finalized Design

IMMERSIVE 180° PROJECTION • ROTATING CHAIR • SCENT + AUDIO + VIBRATION

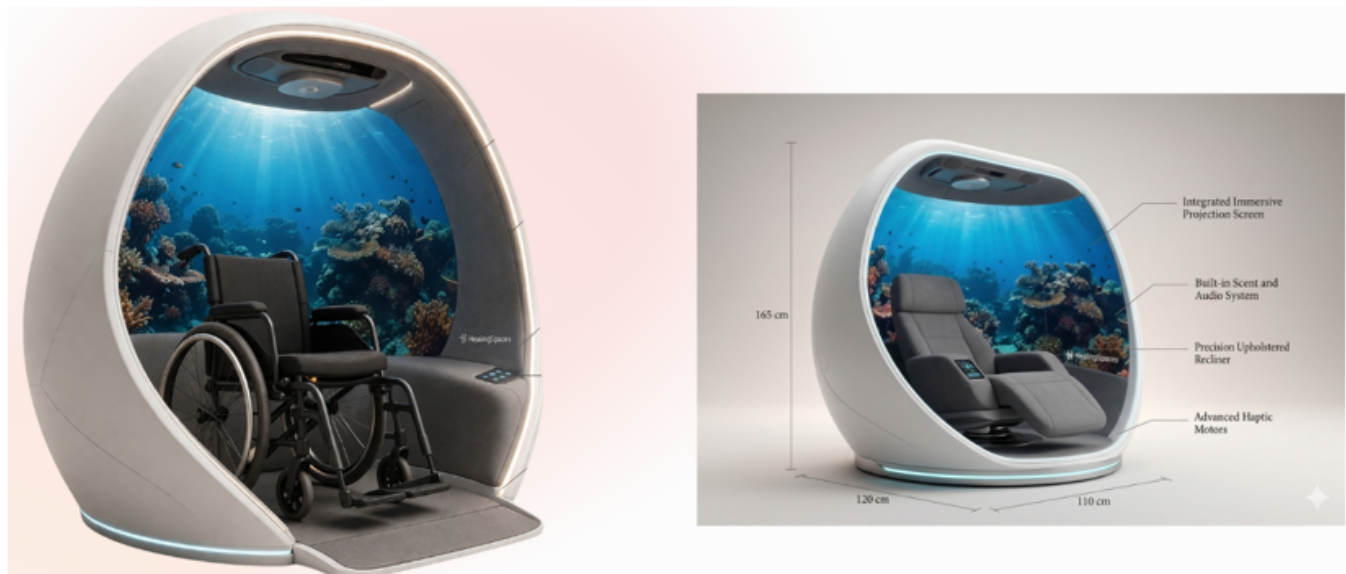
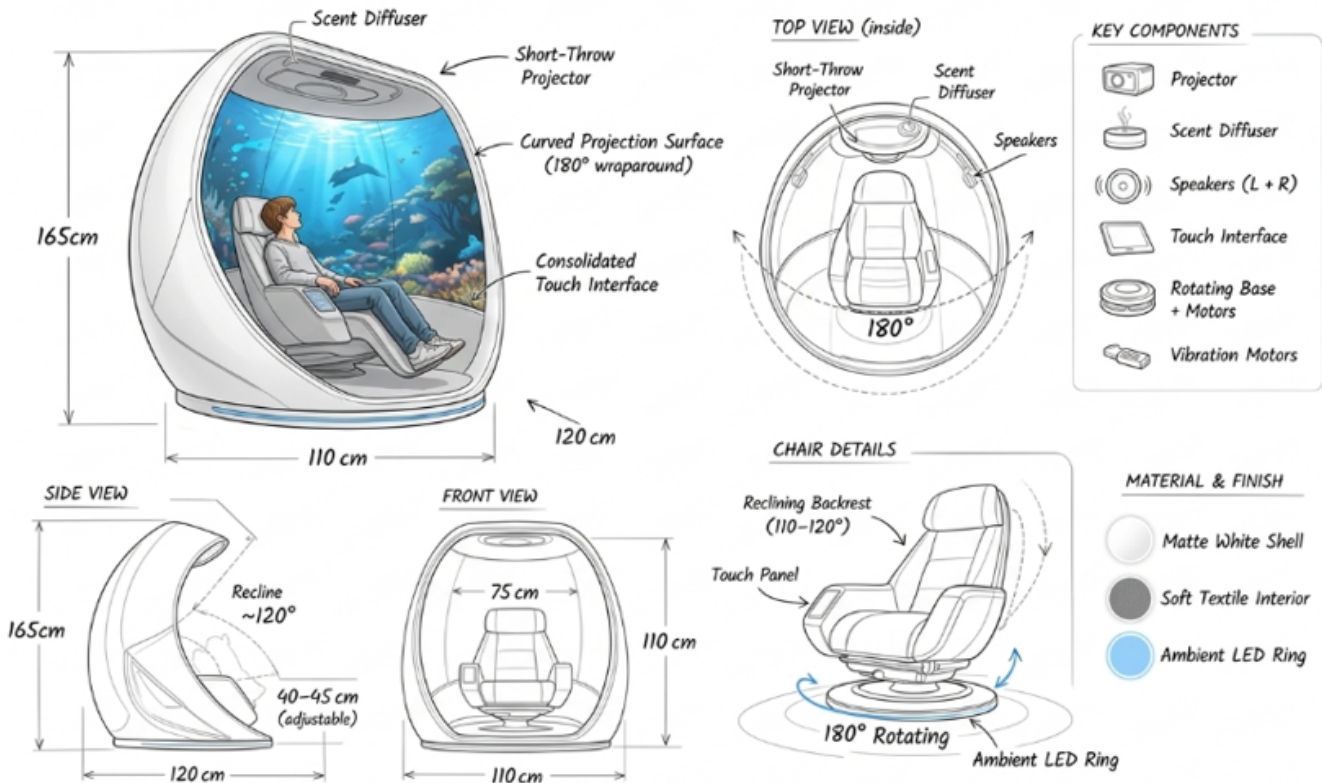

Figure 14: Detailed drawings

(iv) 3D model with load and stress analysis; (v) colour palette.

## Smart System

### Hardware

Include and explain in detail the: (i) black box diagram; (ii) hardware component selection (use tables to compare the different options for each component; (iii) detailed schematics; (iv) power budget.

## Black Box Diagram

This diagram represents a high-level overview of an interactive, multi-sensory system, likely designed for patient therapy, relaxation, or an immersive room experience.

Here is the breakdown of how the different parts interact:

### Inputs

**Cloud:** This section handles remote data. It contains an App and Content that communicate with each other. The cloud sends data, media, or instructions down to the main control unit.

**User/Patient:** This represents the human interaction. The user has a Device to draw (tablet, mobile) that connects to a local App. Whatever the user inputs or draws is sent directly to the central control system.

### Core Processing System

**Controller:** The central microcontroller processes all incoming commands and makes decisions.

**Sensors:** It continuously reads environmental data using various sensors (Light, Motion, Air, CO<sub>2</sub>, Moisture). The controller and the sensors talk to each other to adjust the room's environment based on real-time conditions.

**Outputs / Actuators** **Projector:** Displays visual content (perhaps the drawings from the user's tablet or media from the cloud).

**Scent sprayer:** Releases aromas into the room (using your ultrasonic atomizer).

**Speaker:** Plays audio, music, or sound effects.

### Power Supply

This block shows how electrical energy is distributed. It provides power directly to the central Controller, and it also has dedicated power lines going straight to the output devices (Projector, Scent sprayer, Speaker). This is a very important detail, as high-draw components like projectors and speakers need their own direct power lines rather than drawing current through the main controller.

Figure 15 presents the black box diagram.

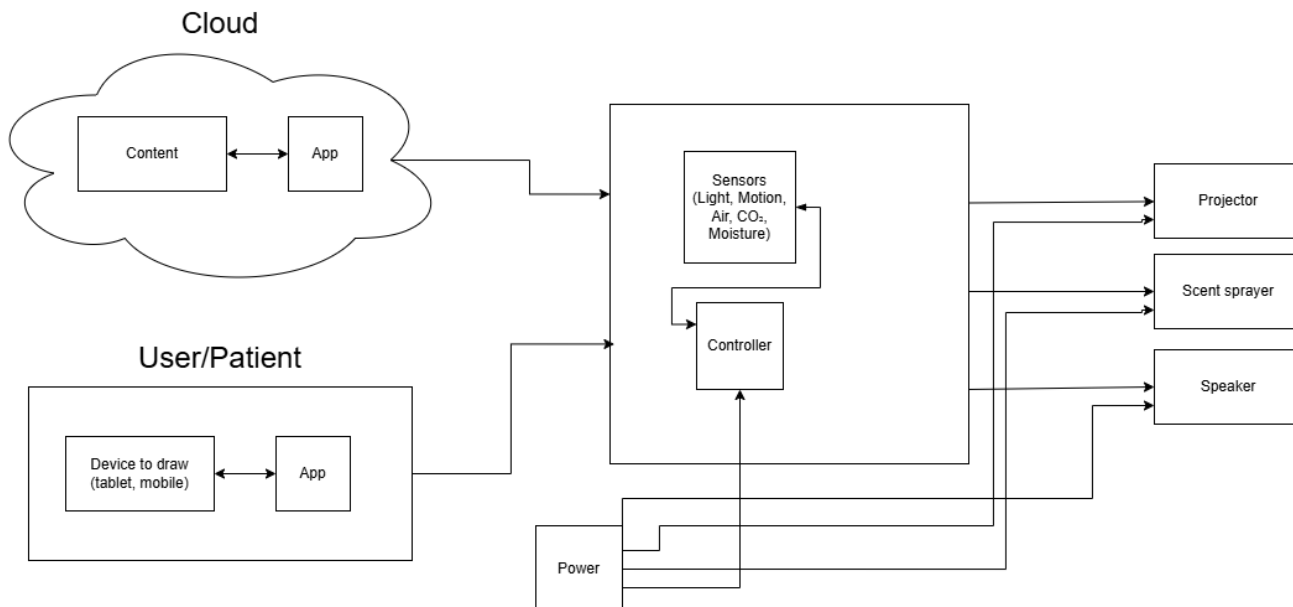

Figure 15: Black box diagram

**Hardware component selection**

Table 4: Bill of Materials

| Name   | Type      | Supplier           | Notes   | Price (€) | Quantity | Total (€) |
|--|-----------|--------------------|---|-----------|----------|-----------|
| ESP32 DevKit V1, ESP32-WROOM-32              | Processor | Farnell            | Dual core 240 MHz, integrated Wi-Fi + Bluetooth. Replaces separate Wi-Fi module.  | 8.75      | 1        | 8.75      |
| Light Sensor, BH1750 (GY-302)                | Sensor    | Botnoll            | I2C digital lux sensor, 0-65535 lux, 3.3 V-5 V. Better than LDR — no conversion needed.   | 1.87      | 1        | 1.87      |
| CO <sub>2</sub> Sensor, MQ-135               | Sensor    | Aquario            | Detects CO <sub>2</sub> , NH <sub>3</sub> , alcohol, benzene, smoke. 10-1000 ppm. Analog + digital output. Compatible 5 V ESP32. Needs 20s warm-up. | 6.09      | 1        | 6.09      |
| Air Humidity and Temp Sensor, DHT22 (AM2302) | Sensor    | Botnoll            | Humidity 0-100 % RH (±2 %) + temperature -40 °C-80 °C (±0.5 °C). Single-wire digital output. 3.3 V-5 V.   | 6.96      | 1        | 6.96      |
| Scent Sprayer, Ultrasonic atomiser 5 V       | Actuator  | electronperdido.es | 108-110 kHz, 5 V USB. Switched via relay. Use with essential oil diluted in water.  | 7.00      | 1        | 7.00      |

| Name                                   | Type     | Supplier                             | Notes  | Price (€) | Quantity | Total (€) |
|--|----------|--------------------------------------|--|-----------|----------|-----------|
| Speaker + Amplifier, MAX98357A         | Actuator | Aquario                              | I2S Class-D amp (2.7 V-5.5 V), directly compatible with ESP32. No external DAC needed. | 11.38     | 1        | 11.38     |
| Relay Module, 5 V single-channel relay | Control  | Ptrobotics                           | Controls power to the ultrasonic atomiser from ESP32 GPIO pin.                         | 4.60      | 1        | 4.60      |
| Power Supply, 5 V 2 A USB adapter      | Power    | Amazon / AliExpress / Any local shop | Powers ESP32 + peripherals. USB power bank also works for portability.                 | 7.26      | 1        | 7.26      |
| Total Cost                             |          |                                      |  |           |          | 53.91     |

### Detailed Schematics

Detailed schematic diagram illustrating the precise electronic connections for the “Healing Cocoon” project. This diagram serves as the electrical blueprint, detailing how the central ESP32-WROOM-32 microcontroller is meticulously wired to interface with the various sensors (temperature, light, and air quality) and actuators (speaker and scent sprayer) essential for the system's function. By following these specific pin connections and component values, the physical interaction described in the system architecture can be realized.

Figure 16 presents the detailed schematics diagram.

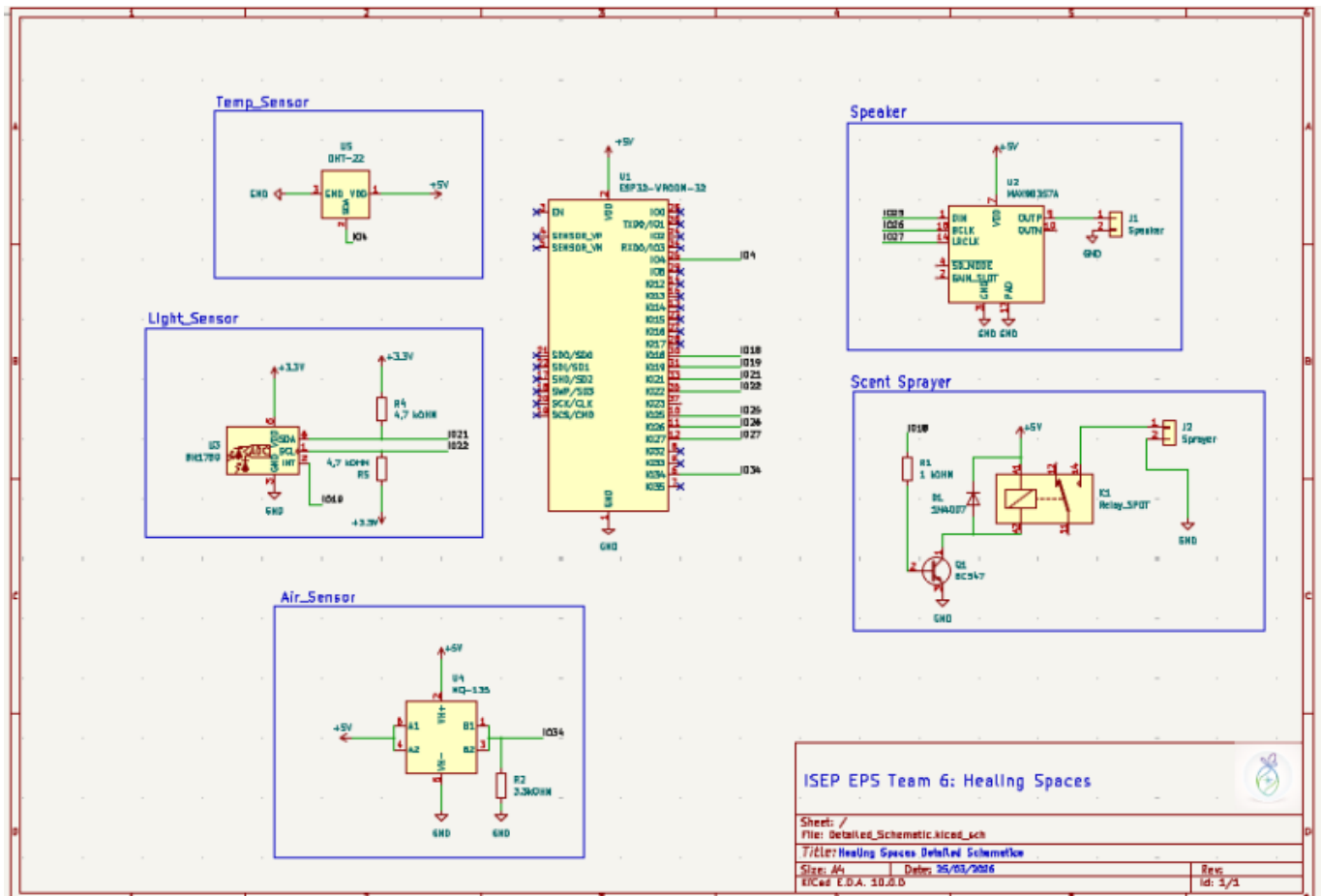

Figure 16: Detailed Schematics

## Power Budget

Power consumption breakdown for the system's components. This table outlines the nominal and maximum values for current (intensity), voltage, and power, providing a clear overview of the electrical requirements and the total system load.

Table 5: Power Consumption Specifications

| Component                   | Intensity [A] | Intensity (max) [A] | Voltage [V] | Voltage(max) [V] | Power [W] | Power (max) [W] |
|-----------------------------|---------------|---------------------|-------------|------------------|-----------|-----------------|
| ESP32 DevKit V1 (WROOM-32)  | 0,08          | 0,5                 | 3,3         | 5                | 0,264     | 2,5             |
| BH1750 (GY-302)             | 0,00014       | 0,001               | 3,3         | 5,5              | 0,000462  | 0,0055          |
| MQ-135                      | 0,15          | 0,16                | 5           | 5,1              | 0,75      | 0,816           |
| DHT22 (AM2302)              | 0,0015        | 0,0025              | 3,3         | 5,5              | 0,00495   | 0,01375         |
| Atomizador Ultrassónico 5 V | 0,3           | 0,5                 | 5           | 5,5              | 1,5       | 2,75            |
| MAX98357A                   | 0,3           | 1,5                 | 2,5         | 5,5              | 0,75      | 8,25            |
| Módulo Relé 5 V (1 Canal)   | 0,07          | 0,09                | 5           | 5,5              | 0,35      | 0,495           |
| TOTAL                       | 0,90164       | 2,7535              | 27,4        | 37,6             | 3,619412  | 14,83025        |

## Software

Describe in detail the: (i) use cases or user stories for the smart device and app; (ii) selection of development platforms and software components (use tables to compare the different options); (iii) component diagram.

## Packaging

Present and explain the: (i) initial packaging drafts; (ii) detailed drawings; (iii) 3D model with load and stress analysis, if applicable.

## Prototype

Refer main changes in relation to the designed solution.

## Structure

Detail and explain any changes made in relation to the designed solution, including structural downscaling, different materials, parts, etc.

## Hardware

Detail and explain any change made in relation to the designed solution. In case there are changes

regarding the hardware, present the detailed schematics of the prototype.

## Software

Detail and explain any changes made in relation to the designed solution, including different software components, tools, platforms, etc.

The code developed for the prototype (smart device and apps) is described here using code flowcharts.

## Introduction

For this project, a web-based prototype was developed to simulate how users interact with the Healing Cocoon system.

The main goal of this prototype is to show how the system would work in practice. The focus is mainly on the user experience and the overall flow, rather than on a fully developed technical solution.

It is important to note that this is a first demo version. The application can still be improved and expanded in future iterations.

## Technologies & Tools

The prototype was built using simple and accessible technologies:

- HTML for the structure
- CSS for the design and layout
- JavaScript for basic interactivity

No frameworks such as React were used. This decision was made to keep the system simple and easy to understand, especially for a first prototype.

The design follows a clean and modern style, inspired by medical and product interfaces, with a focus on clarity and ease of use.

## Application Overview

The application is divided into two main user roles:

- Staff users (clinic or practice staff)
- Child users (end users of the cocoon)

The staff uses a dashboard to manage the system and set up sessions, while the child interacts with a much simpler interface designed to be intuitive and calming.

## Screens & Explanation

### Login page

Figure 17 presents the login for our application.

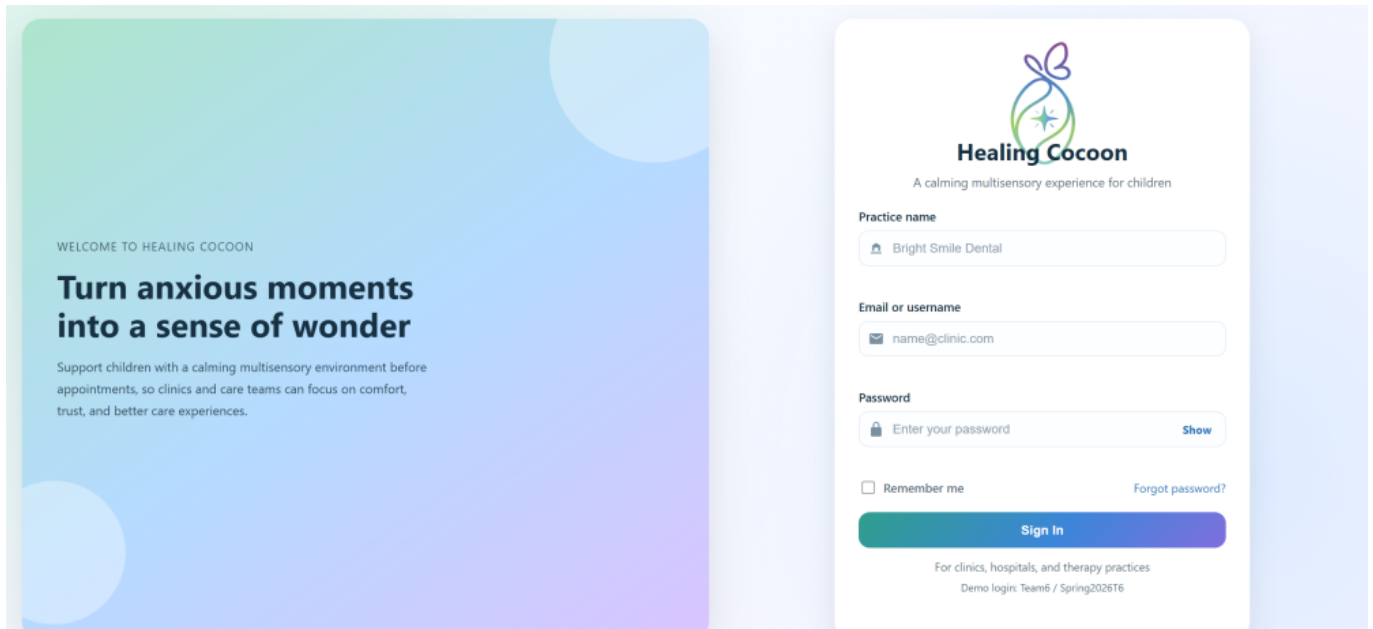

Figure 17: Login interface of Healing Cocoon

The login page allows staff members to access the system using their practice credentials.

It includes fields for:

- Practice name
- Username or email
- Password

This ensures that only authorized users can manage the cocoon.

### Dashboard

Figure 18 refers the dashboard interface 1.

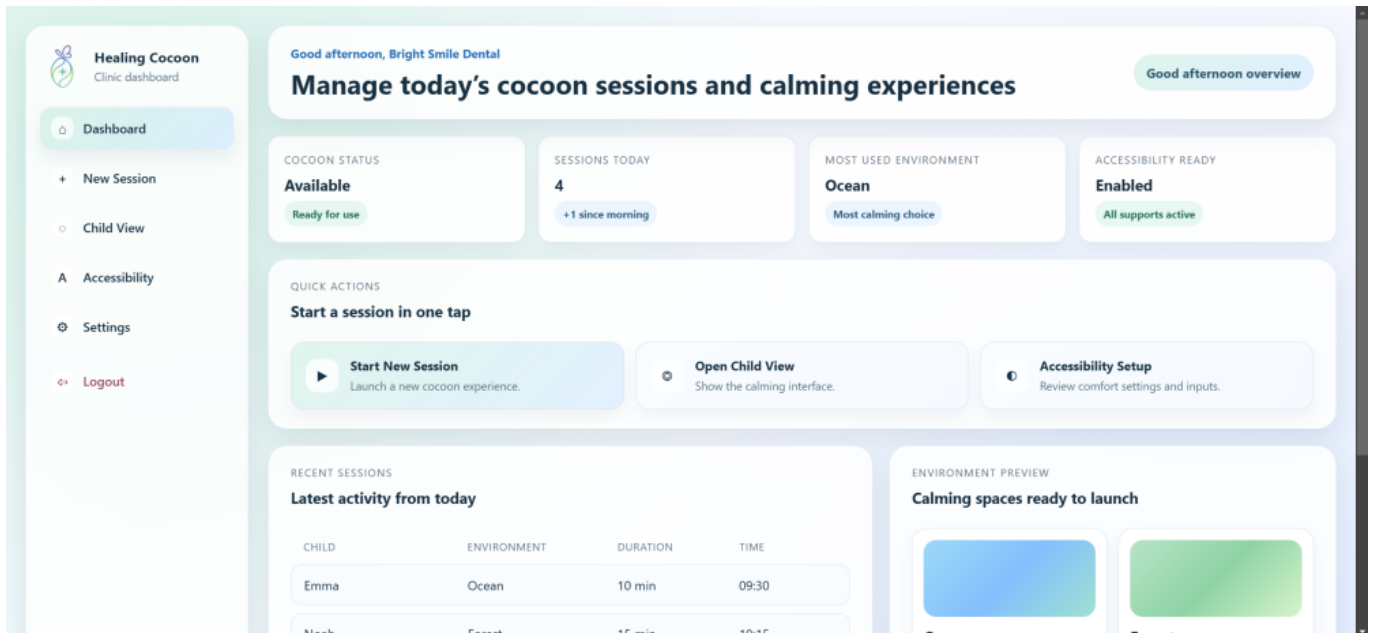

Figure 18: Dashboard overview interface 1

Figure 19 refers the dashboard interface 2.

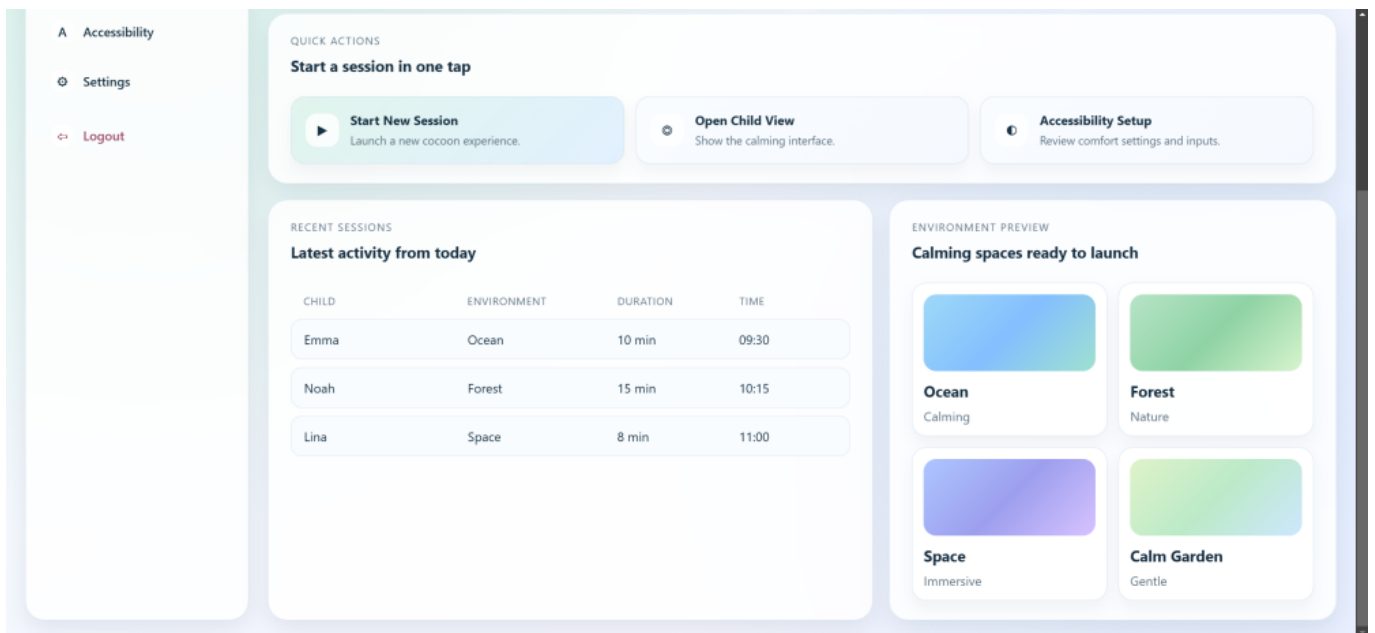

Figure 19: Dashboard overview interface 2

The dashboard gives a general overview of the system.

It shows:

- The current status of the cocoon
- The number of sessions for the day
- The most used environment
- Accessibility status

From this page, staff can quickly navigate to other parts of the application or start a new session.

## New Session page

Figure 20 presents the new session configuration 1.

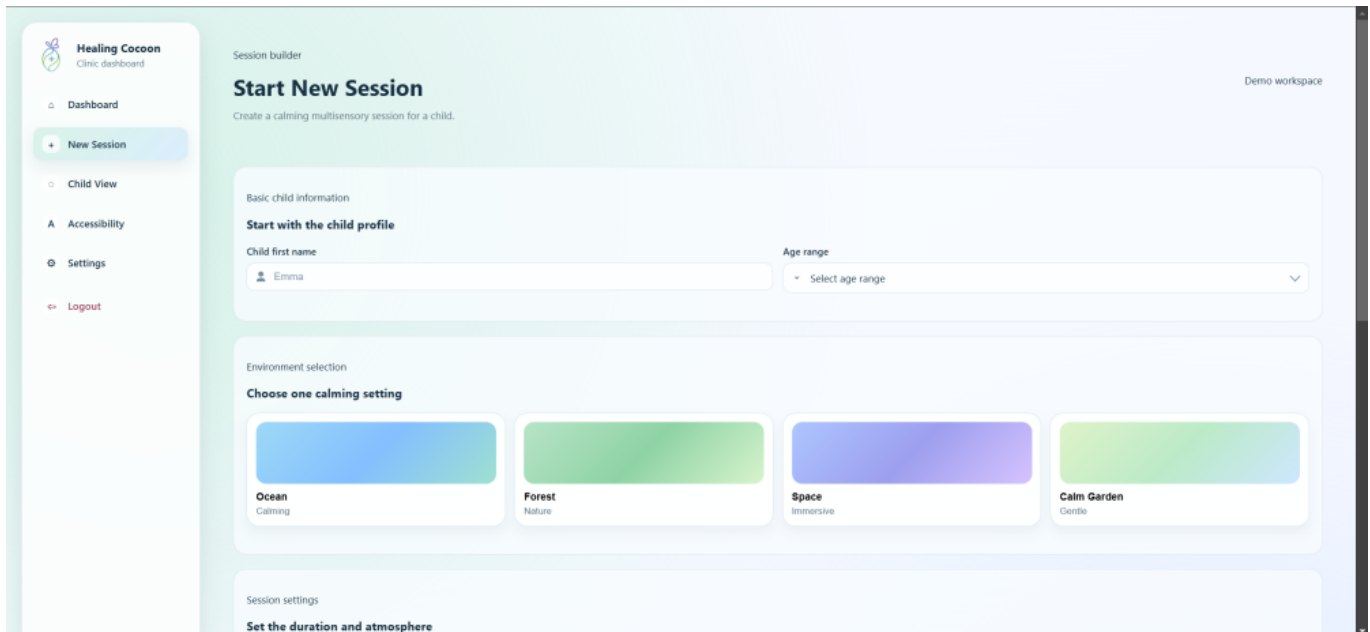

Figure 20: New session configuration page

Figure 21 presents the new session configuration 2.

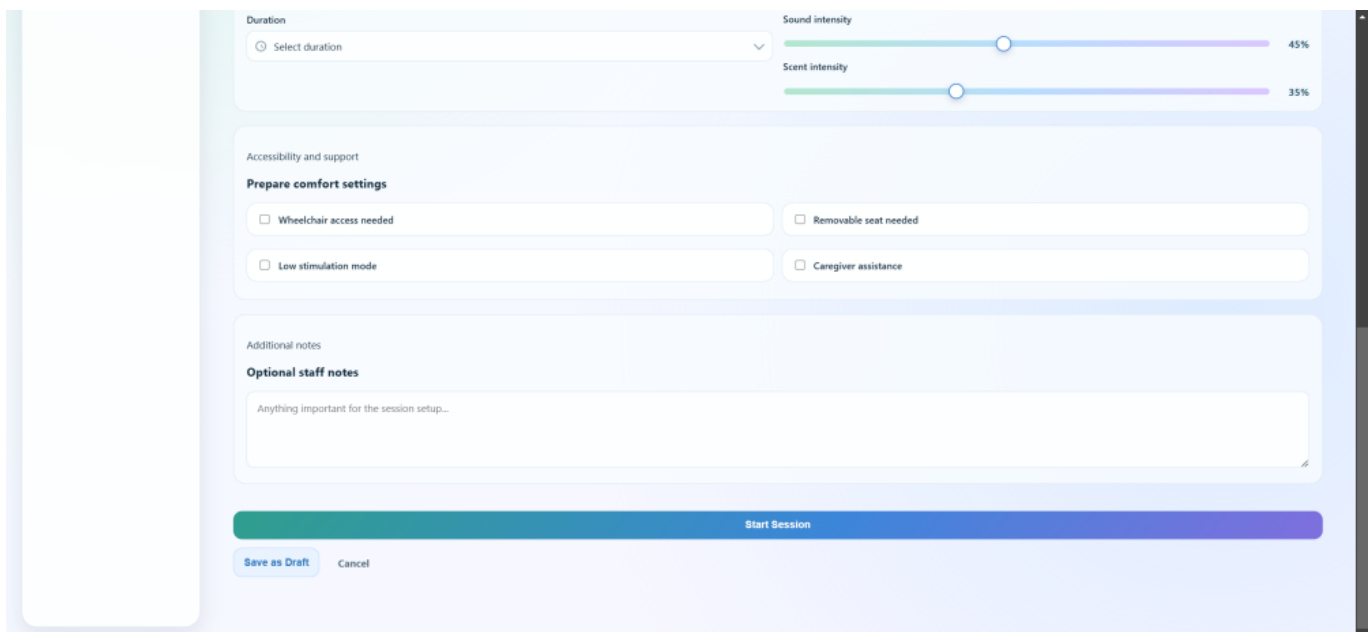

Figure 21: New session configuration page 2

This page is used to create a new session for a child.

The staff can:

- Enter the child’s name
- Select an environment (such as Ocean, Forest, or Space)
- Adjust sound and scent levels
- Set the duration of the session
- Enable accessibility options if needed

This is the main functionality of the system.

## Active Session page

Figure 22 presents active session interface 1.

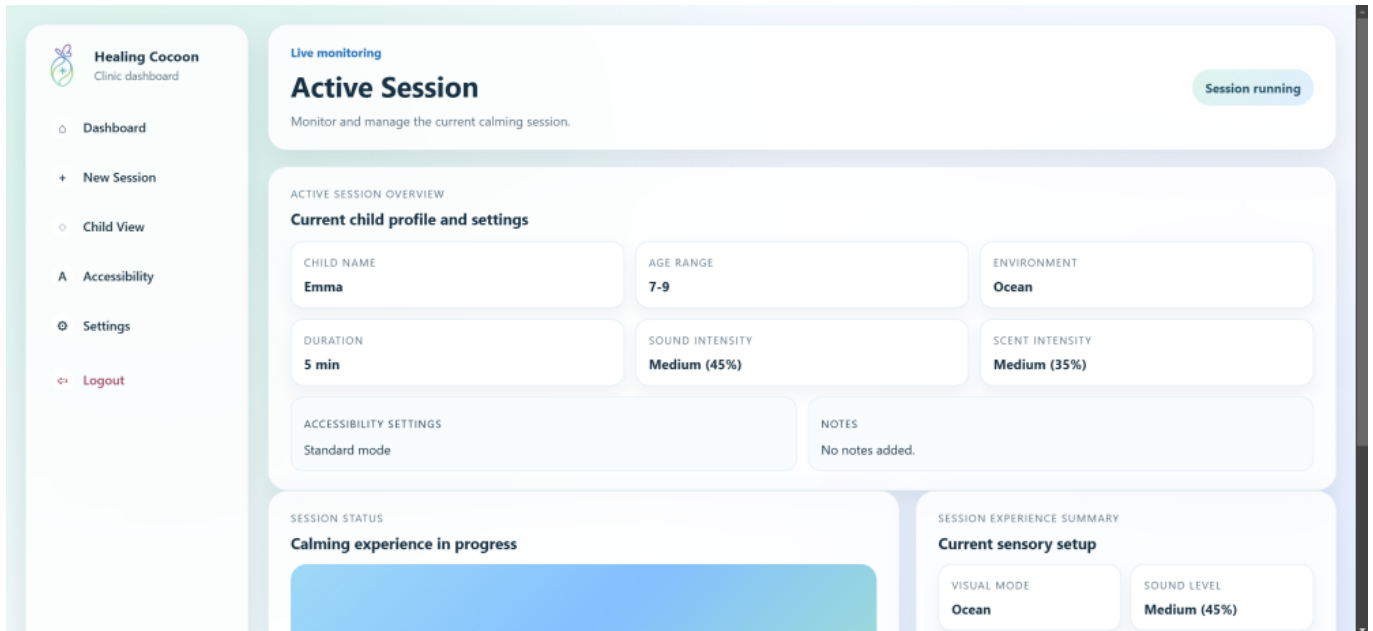

Figure 22: Active session monitoring interface 1

Figure 23 presents the new session configuration 2.

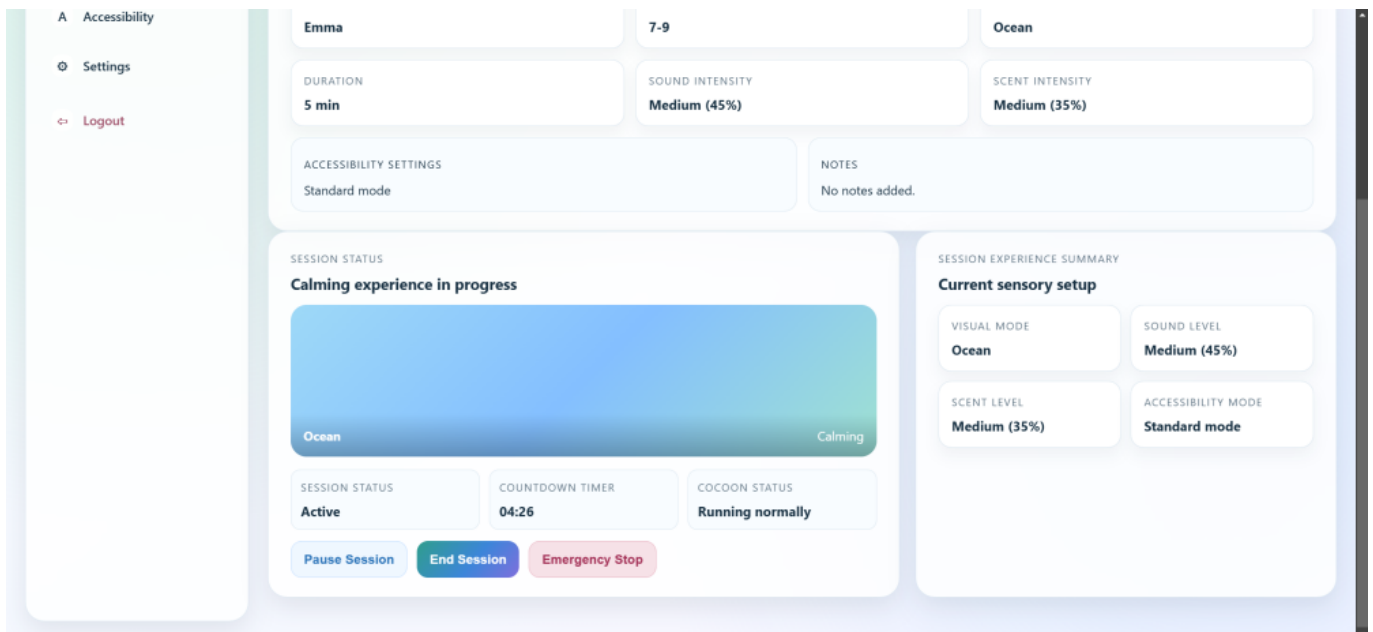

Figure 23: Active session monitoring interface2

This page displays the currently active session.

It shows:

- The selected environment
- A countdown timer

- The chosen sound and scent levels

It also includes controls to:

- Pause the session
- End the session
- Activate an emergency stop

### Child View

Figure 24 refers to child interaction interface 1.

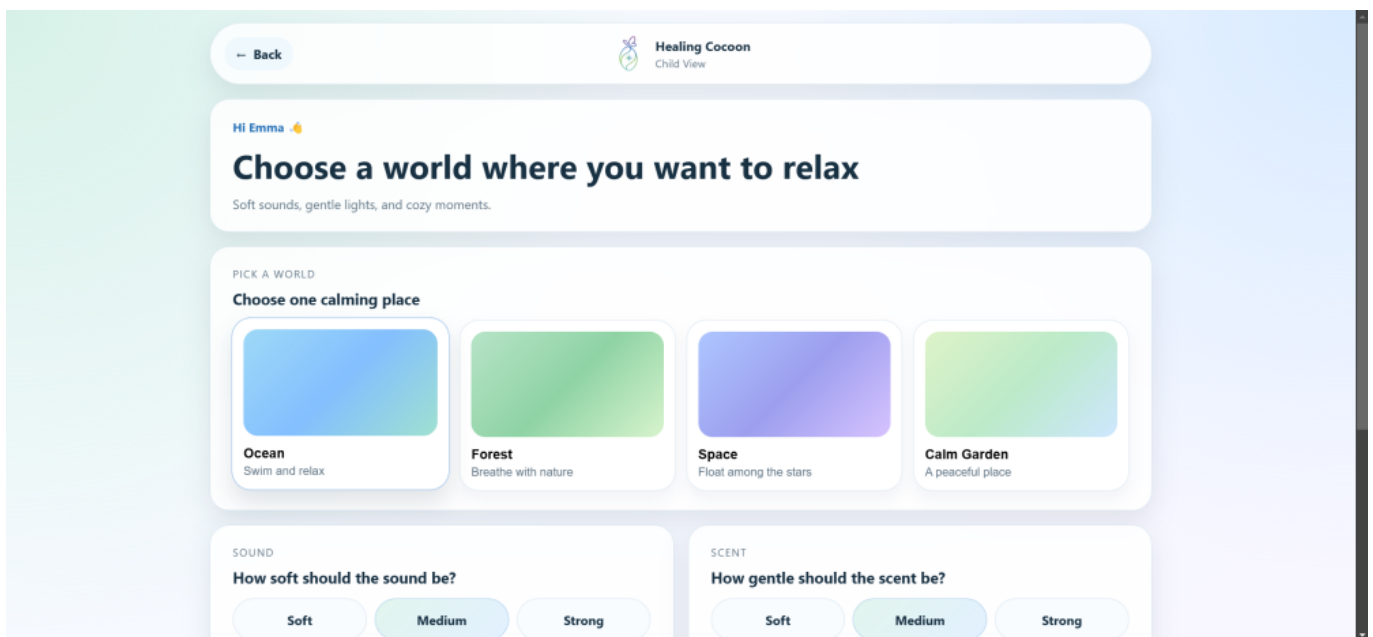

Figure 24: Child interaction interface 1

Figure 25 presents the new session configuration 2.

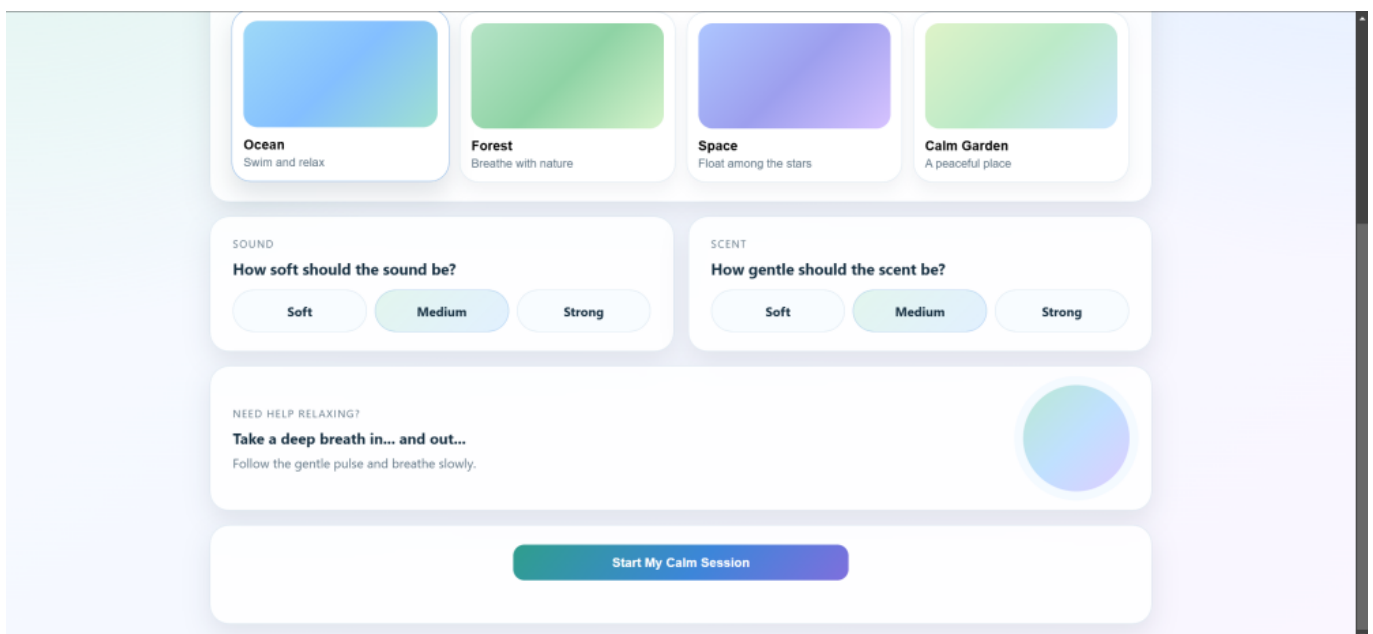

Figure 25: Child interaction interface 2

The child view is designed to be simple and easy to use.

It focuses mainly on visual elements and avoids too much text. The child can choose a calming environment and start the session in a straightforward way.

## Accessibility page

Figure 26 presents the accesibility settings interface 1.

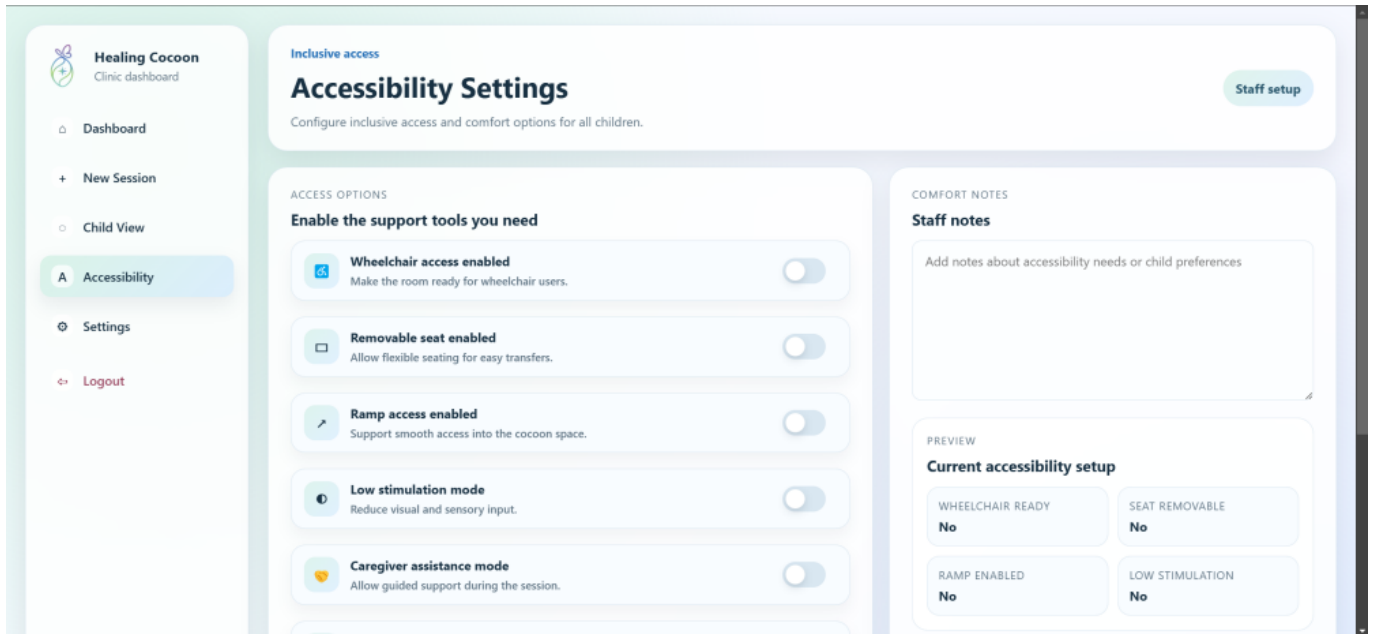

Figure 26: Accessibility settings interface 1

Figure 27 presents the accesibility settings interface 2.

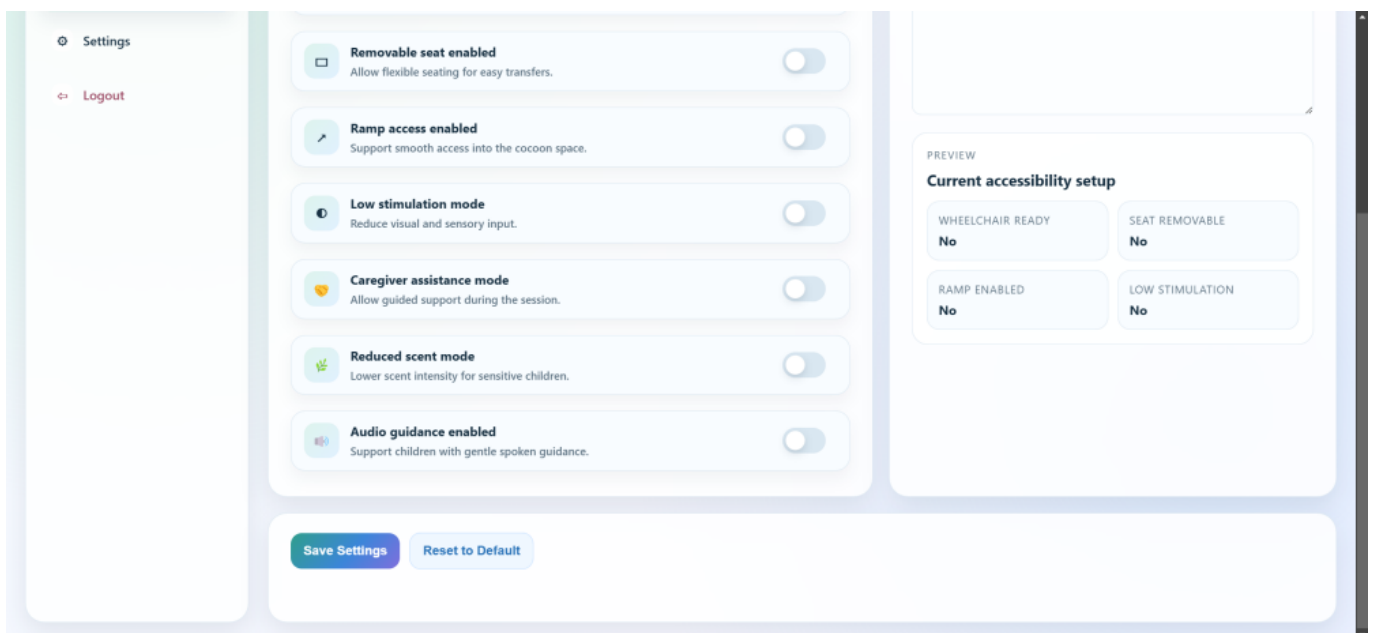

Figure 27: Accessibility settings interface 2

This page allows staff to configure accessibility options.

For example:

- Wheelchair access
- Removable seat
- Low stimulation mode

This ensures that the system can be used by as many children as possible.

## Settings page

Figure 28 refers to settings interface 1.

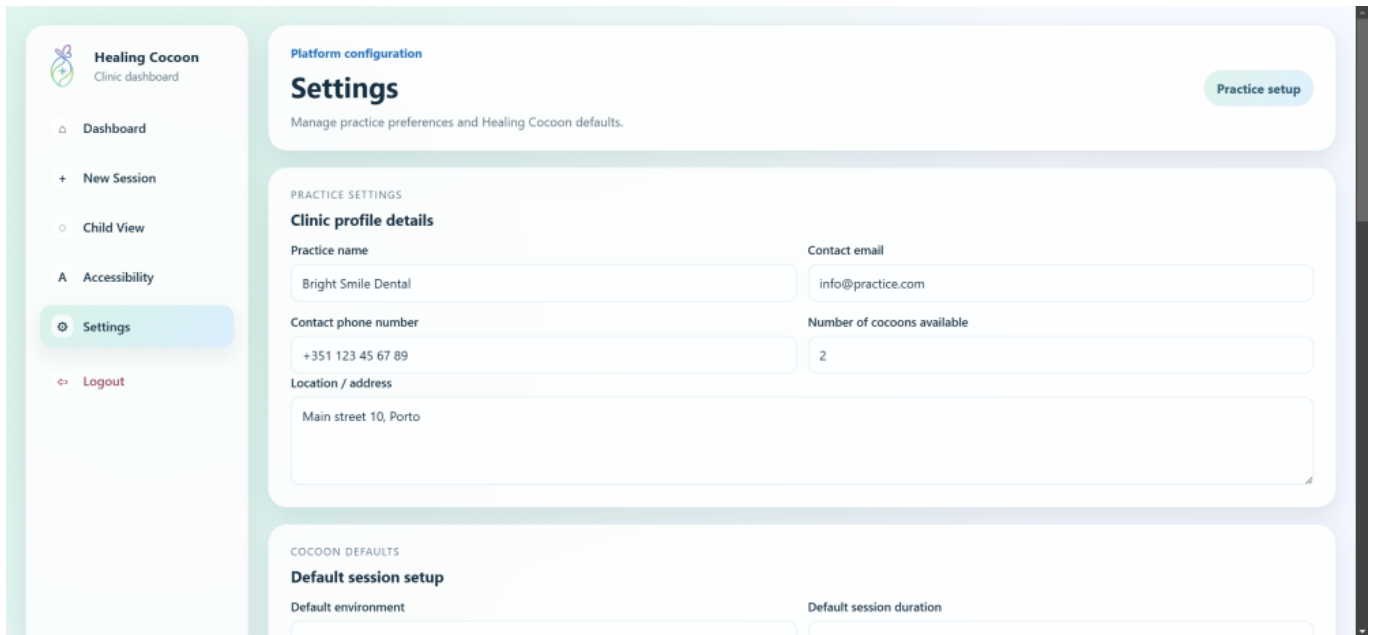

Figure 28: System settings interface 1

Figure 29 refers to settings interface 2.

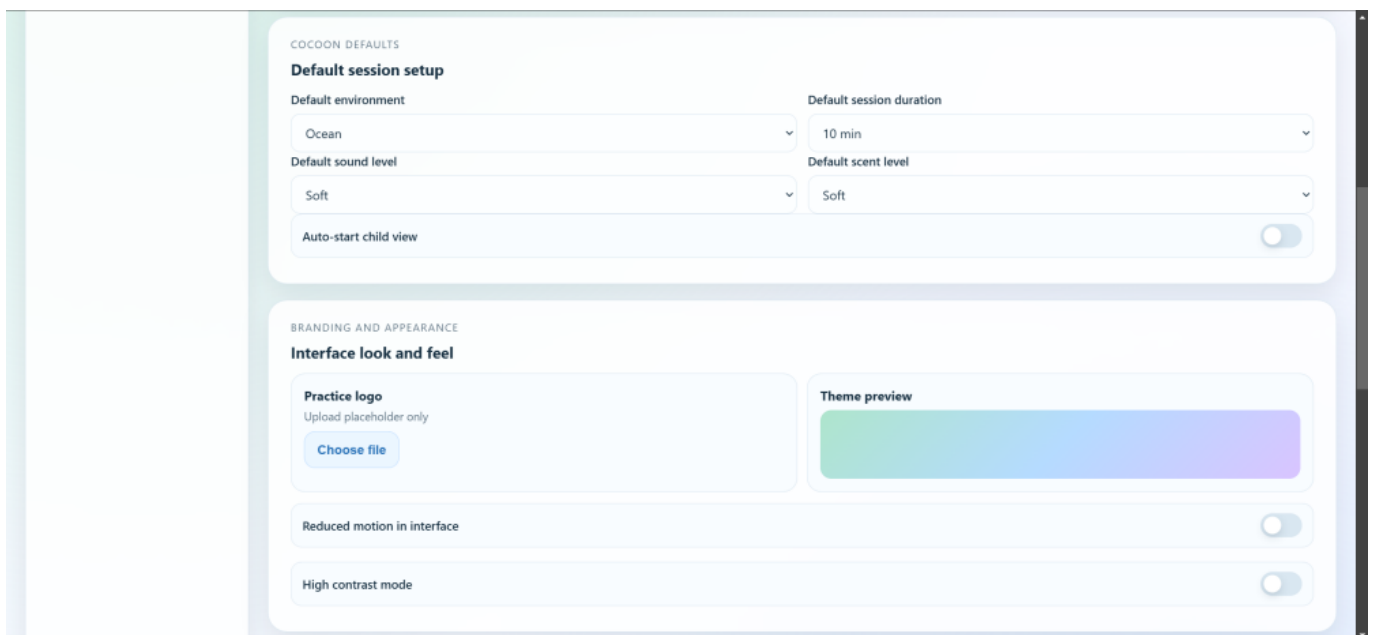

Figure 29: System settings interface 2

Figure 30 refers to settings interface 3.

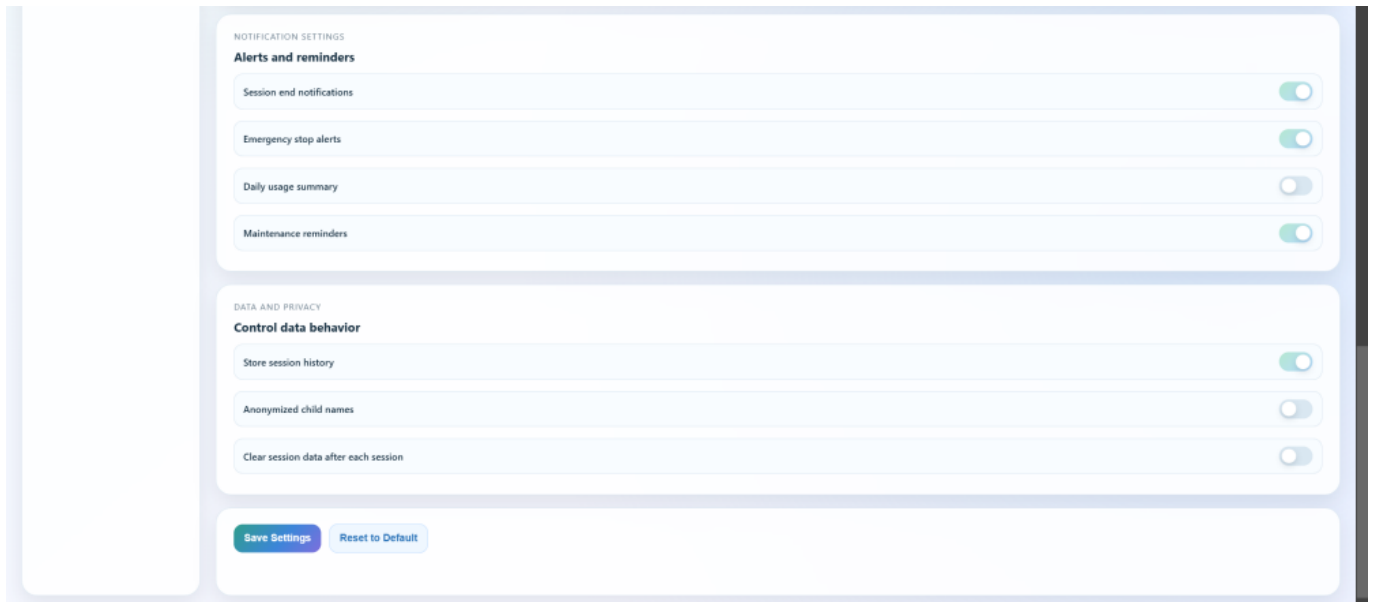

Figure 30: System settings interface 3

The settings page is used to manage general system preferences.

It includes:

- Practice information
- Default session settings
- Notification options
- Basic data and privacy settings

## Code flow

The prototype uses a simple front-end logic.

First, the staff logs into the system. Then, a new session is created and the selected data is stored using LocalStorage. The active session page reads this data and displays it.

The child then interacts with the system through the child view.

This approach makes it possible to simulate a working system without using a backend.

## Future improvements

This prototype is only a first version and can be further improved.

Possible future improvements include:

- Integration with real hardware (such as projectors and scent systems)
- Adding a backend with a database and authentication
- Real-time communication between components
- More advanced personalization for children

## Tests & Results

### Hardware tests

Perform the hardware tests specified in [Tests](#). These results are usually presented in the form of tables with two columns: Functionality and Test Result (Pass/Fail).

### Software tests

Software tests comprise: (i) functional tests regarding the identified use cases / user stories; (ii) performance tests regarding exchanged data volume, load and runtime (these tests are usually repeated 10 times to determine the average and standard deviation results); (iii) usability tests according to the [System Usability Scale](#).

## Summary

*Provide here the conclusions of this chapter and make the bridge to the next chapter.*

2026/02/16 21:11 · epsatissep · [0 Comments](#)

## Conclusions

### Achievements

*Discuss here what was achieved (wrt the initial objectives) and what is missing (wrt the initial objectives) of the project.*

### Limitations

*Identify here the limitations of the solution and prototype.*

### Future Development

*Provide here your recommendations for future work.*

2026/02/16 21:12 · epsatissep · [0 Comments](#)

# Acknowledgements

2026/02/16 22:33 · epsatissep · [0 Comments](#)

## Bibliography

Will be added automatically by citing, in the body of the report, entries specified in BibTeX format and stored in the <https://www.eps2026-wiki6.dee.isep.ipp.pt/doku.php?id=refnotes:bib> file

PS - If you have doubts on how to make citations, create captions, insert formulas, etc. visit this [page](#) with examples and select "Show pagesource" to see the source code.

- 
- [1] R.Salvato S.De Giorgio R.Gatto S.Caruso A.Montedori I.Abraha S.Pagano E.Lupatelli G.Lombardo S.Cianetti, 2017. [Dental fear/anxiety among children and adolescents. A systematic review. PubMed](#), 18, pp.121-130.
- [2] Jianghe Xu Xinyu Deng Yi Wang, 2025. [The Impact of Color—Light Interaction Design in Hospital Waiting Areas on Emotional Relaxation. ACM Digital library](#), pp.1085 - 1092, ISSN 2214-7853.
- [3] L. Deecke, P. Jöhren S. Lehr G. Marwinski J. Lehrner. [Ambient odors of orange and lavender reduce anxiety and improve mood in a dental office. ScienceDirect](#), 86.
- [4] Maartje de Graaf Thirza Hiwat Anouk Neerincx, 2021. [Social Robot for Health Check and Entertainment in Waiting Room: Child’s Engagement and Parent’s Involvement.. ACM Digital Library](#), pp.120 - 125.
- [5] Jeroen S Legerstee Bram Dierckx Manon H J Hillegers René M H Wijnen Johan M Berghmans Pieter F A de Nijs Lonneke M Staals Elisabeth M W J Utens Robin Eijlers, 2019. [Systematic Review and Meta-analysis of Virtual Reality in Pediatrics: Effects on Pain and Anxiety. PubMed National Library of Medicine](#), 129, pp.1344-1353.
- [6] Xiao-li Chen PhD Qin Zhang BN Wen-yan Yao MM Rong Qiu MM Yun Hua MM, 2015. [The Effect of Virtual Reality Distraction on Pain Relief During Dressing Changes in Children with Chronic Wounds on Lower Limbs. ScienceDirect](#), 16, pp.685-691.
- [7], [12] H.S.M. Kort J. van Hoof E. Morales E.R.C.M. Huisman, 2012. [Healing environment: A review of the impact of physical environmental factors on users. ScienceDirect](#), 58, pp.70-80.
- [8], [11] Wei Wei Yuhang Xu Bing Zhao Yujun Ding Hongyi Li, 2023. [Effects of immersion in a simulated natural environment on stress reduction and emotional arousal: A systematic review and meta-analysis. PubMed National Library of Medicine](#).
- [9] LuShun Zhang Li Cheng MeiLin Zhu YaXuan Wang Yi Cheng Jiao Chen LanXin Zhang JingXin Yan JiaXin Wu, 2022. [The effectiveness of distraction as preoperative anxiety management technique in pediatric patients: A systematic review and meta-analysis of randomized controlled trials. ScienceDirect](#), 130.
- [10], [19] Chaza Kouchaji Nada Bshara Laith Alsabek Amer Owayda M-Nour Alhalabi Zuhair Al-Nerabieah, 2020. [Effectiveness of using virtual reality eyeglasses in the waiting room on preoperative anxiety: A Randomized Controlled Trial.. ScienceDirect](#), 21.
- [13] Ann Sloan Devlin, Allison B. Arneill, 2003. [Health Care Environments and Patient Outcomes: A Review of the Literature. Environment and Behavior](#), 35, pp.665-694.
- [14] Philips Company. [Philips Ambient Experience](#). .
- [15] [Qwiek.up for healthcare professionals](#). .
- [16] SyncVr Medical. [Improving care with Virtual Reality](#). .
- [17] Nicole Witowski, 2025. [How design in clinical spaces may influence health outcomes. Definitive Healthcare](#).

- [18] Judy Rollins, 2004. Evidence-based hospital design improves health care outcomes for patients, families, and staff. *ResearchGate - PubMed*.
- [20] Sebastian Zupok, Michal Kapala, 2025. Next Generation Marketing Channels: Typology, Strategic Implications, and the 6V Framework. *European Research Studies Journal*, XXVIII, pp.576-590.
- [21] Anabel Ternès Noha El-Bassiouny Sara Hamed, 2017. Evidence-Based Design and Transformative Service Research application for achieving sustainable healthcare services: A developing country perspective. *ScienceDirect*, 140, pp.1885-1892.
- [22] Kimihiro Sakagami Jorge P.Arenas, 2020. Sustainable Acoustic Materials. *MDPI*, 12.
- [23] Samuele Schiavoni Francesco D'Alessandro Francesco Asdrubali, 2015. A review of unconventional sustainable building insulation materials. *ScienceDirect*, 4, pp.1-17.
- [24] Chun Zhang Changyin Sun Lei Xue Fang Yu, 2016. Product transportation distance based supplier selection in sustainable supply chain network. *ScienceDirect*, 137, pp.29-39.
- [25] Alan Lewis Verena Ehrler Daniel Diekmann Igor Davydenko Uwe Clausen Heidi Auvinen, 2014. Calculating emissions along supply chains — Towards the global methodological harmonisation. *ScienceDirect*, 12, pp.41-46.
- [26], [31] F. Marques da Silva S.A., 2022. Aluminium shapes. .
- [27], [30] F. Marques da Silva S.A., 2022. Brass sheet. .
- [28], [32] Artnovion, 2026. Acoustic\_dBA UL-Foam. .
- [29], [33] Monteiro Fabrics. Monteiro Fabrics - MEDIFLEX Collection. .

From:

<https://www.eps2026-wiki6.dee.isep.ipp.pt/> - **EPS@ISEP**

Permanent link:

<https://www.eps2026-wiki6.dee.isep.ipp.pt/doku.php?id=report>

Last update: **2026/03/18 14:21**

